

DELL EMC ISILON ONEFS OPERATING SYSTEM

Powering scale-out NAS for the Big Data and Object workloads of today and tomorrow

ESSENTIALS

- Easy-to-use, single volume, single file system architecture
- Seamless integration of flash, hard disk and cloud
- Highly scalable with grow-as-you-go flexibility
- Unmatched efficiency
- Multiprotocol support to maximize operational flexibility
- Enterprise data protection and resiliency for your valuable data
- Robust security and data encryption options
- Built on a scale-out data lake

DELL EMC ISILON ONEFS

The Dell EMC Isilon OneFS operating system provides the intelligence behind all Isilon scale-out storage systems. It combines the three layers of traditional storage architectures—file system, volume manager, and data protection—into one unified software layer, creating a single intelligent file system that spans all nodes within a cluster.

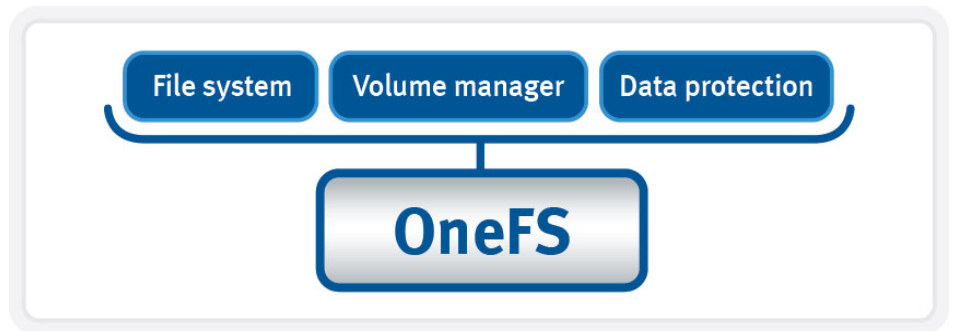

The OneFS operating system powers Isilon scale-out storage solutions and provides a massively scalable, high-performance, modular storage architecture that can grow easily with your business. With built-in interoperability, OneFS can help you accelerate a wide range of processes and workflows, while providing the highest levels of data protection available. With OneFS, the organizations can extend the data lake to the cloud and to enterprise edge locations to consolidate and manage data more effectively, easily gain cloud-scale storage capacity, reduce overall storage costs, increase data protection and security, and simplify management of unstructured data.

EASE OF USE FOR STREAMLINED MANAGEMENT

OneFS has been designed to simplify administration activities and maintain this simplicity as you scale your Isilon storage system. OneFS is a single file system, single volume architecture, which makes it extremely easy to manage, regardless of the number of nodes in your Isilon storage cluster. Isilon storage systems powered by OneFS are simple to install, manage, and scale to virtually any size whether you use all flash or hard disk storage or any combination in between.

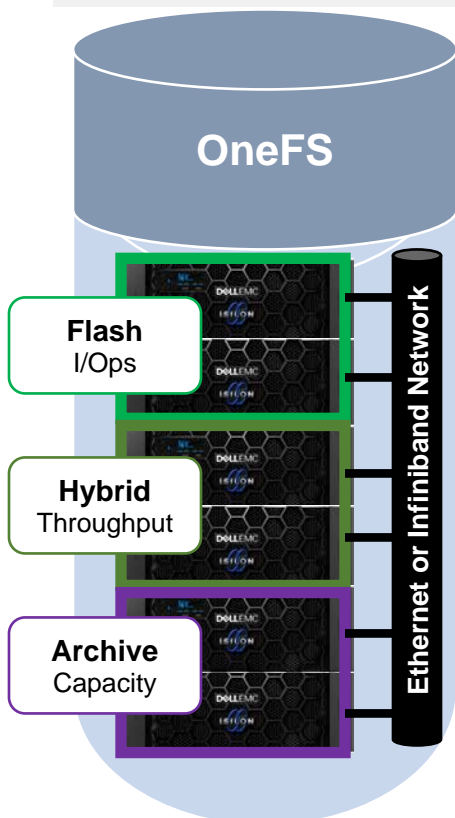

MASSIVE SCALABILITY FOR GROWING BIG DATA AND OBJECT STORAGE ENVIRONMENTS

In contrast to stand-alone storage systems that must “scale up” when additional performance or capacity is needed, OneFS enables an Isilon storage system to “scale out,” seamlessly increasing the existing file system or volume into petabytes of capacity. Isilon storage systems can scale to over 68 PB in a single file system. OneFS allows a storage system to grow symmetrically or independently as more space or processing power is required—providing a grow-as-you-go approach and the ability to scale out as your business needs dictate.

Increasing the storage capacity and performance capabilities of an Isilon cluster can be done quickly and easily. Nodes can be added to the file system and be ready to use in minutes—versus a traditional file system, which can take hours to install, configure, and provision. With OneFS, you can quickly and easily add nodes without downtime or manual data migration, thereby saving precious IT resources. OneFS also provides automatic non-disruptive disk firmware upgrades to facilitate lights-out operations. OneFS provides non-disruptive upgrades with no loss of connectivity during the upgrade process. In addition, OneFS provides rollback capability that will allow the administrators to do an upgrade and then decide if they want to revert or rollback the upgrade. This non-disruptive upgrade feature of OneFS minimizes the user impact and enables continuous availability during the upgrade process.

UNMATCHED EFFICIENCY AND COST-SAVINGS

OneFS utilizes an Isilon AutoBalance™ function to automatically reallocate and rebalance data and make storage space more usable and efficient. AutoBalance eliminates on-disk hot spots automatically and enables Isilon storage systems to provide over 80 percent utilization with a single pool of shared storage. To further increase storage efficiency, Isilon SmartDedupe™ offers a data deduplication option, reducing storage requirements by up to 35 percent in environments with redundant data across multiple sources. This industry-leading storage efficiency, combined with the simple and easy-to-manage OneFS operating system, helps you to reduce capital expenditures as well as ongoing operating costs.

With OneFS and Isilon SmartPools® software, you can further optimize your Isilon network-attached storage (NAS) for performance and economy using automated storage tiering and a policy-based approach to automatically move inactive data to more cost-effective storage. With a choice of flash or hard disk, your choice of storage can flexibly meet your business needs. This streamlines workflows for your most current data, while remaining completely transparent to users and applications.

With Isilon CloudPools software, you can seamlessly integrate your Isilon cluster to the cloud for your cold or frozen data. CloudPools provides you virtually unlimited amount of storage by tiering inactive files to your choice of public or private cloud options including Microsoft Azure, Amazon AWS S3, Dell EMC ECS, Dell EMC Virtustream, or Isilon.

SIMPLE AND FLEXIBLE INTEROPERABILITY FOR BUSINESS AGILITY

OneFS provides integrated support for a wide range of industry-standard protocols, including Internet Protocols IPv4 and IPv6, network file system (NFS), Server Message Block (SMB), Hypertext Transfer Protocol (HTTP), File Transfer Protocol (FTP), OpenStack Swift, REST-based Object access for your cloud initiatives and Hadoop Distributed File System (HDFS) for fast and efficient in-place analytics. This allows you

to greatly simplify and consolidate workflows, increase flexibility, and get more value from your enterprise applications. With OneFS, you can streamline your storage infrastructure by consolidating large-scale file and unstructured data assets, as well as eliminate silos of storage. With this scale-out data lake approach, you can efficiently store and manage data that supports a wide range of applications for both traditional workloads as well as emerging workloads like mobile computing, cloud applications and Hadoop analytics.

OneFS, the first scale-out NAS platform to provide native HDFS support, helps you address your Big Data storage and business analytics needs. This means that with Isilon storage, you can readily use your Hadoop data with other enterprise applications and workloads, while eliminating the need to manually move data around or manage a dedicated infrastructure that is not integrated with or connected to any other applications, as you would need to do with a direct-attached storage approach. This integration simplifies your business analytics initiatives and helps you leverage results faster. OneFS includes support for a number of commercial Hadoop deployments from vendors like Pivotal, Cloudera, IBM, and HortonWorks. Isilon also support Apache Ambari for provisioning, management, and monitoring of Hadoop environments and Ranger for authentication management by Hadoop administrators

To provide a robust control interface for your Isilon storage systems, OneFS incorporates a platform API that directly interfaces with the Isilon file system and allows you to gain an even more robust control interface to the Isilon cluster. The Isilon platform API is a REST-based HTTP interface for automation, orchestration, and provisioning of an Isilon cluster. With the platform API, third-party applications can be used to control the administrative capabilities within OneFS, thereby further simplifying management, data protection, and provisioning. An Isilon SDK is published and continuously updated on github for rapid tool development and easy integration of Isilon into your existing management frameworks.

These levels of interoperability are designed to help you leverage your large data assets more flexibly with a broad range of applications and workloads, as well as across a diverse IT infrastructure environment.

OneFS includes support for OpenStack Swift based object storage solutions that enable next-generation workloads. Support for OpenStack Swift enables customers to run cloud-based applications on Isilon. OneFS provides simultaneous native support for file, Hadoop, and object-based workloads.

REACH NEW LEVELS OF PERFORMANCE

To support your most demanding applications and workloads, Isilon solutions powered by OneFS, delivers up to 9 million file IOPS and 540 GB/s concurrent throughput per cluster. This allows data to be ingested and delivered very quickly to high-performance applications and servers.

A large-scale storage system must provide the performance required for a variety of workflows, whether they be sequential, concurrent, or random. Different workflows will exist between applications and within individual applications. OneFS provides for all of these needs simultaneously with intelligent software. Another important advantage of Isilon scale-out storage is that throughput and I/O per second scale linearly with the number of nodes present in a single system. This means that as your Isilon storage environment grows, performance increases linearly, unlike traditional systems.

To drive increased performance for workloads that have a lot of random read I/O, OneFS enables a scale-out flash tier. Because the scale-out flash tier is self-configuring and self-optimizing, it is extremely easy to set up and requires little or no administrative overhead. In addition, customers can deploy a complete flash solution with the new F800 All-Flash array for maximum performance and capacity to meet demanding workloads

With OneFS, Isilon was the first scale-out NAS platform to support SMB 3.0 Multi-Channel which allows a suitably configured Windows 8 or Windows Server 2012 or later client to connect to an Isilon cluster and take advantage of the enhanced performance and reliability capabilities. OneFS also supports SMB 3.0 Continuous Availability protocol to provide non-disruptive operations for Windows clients

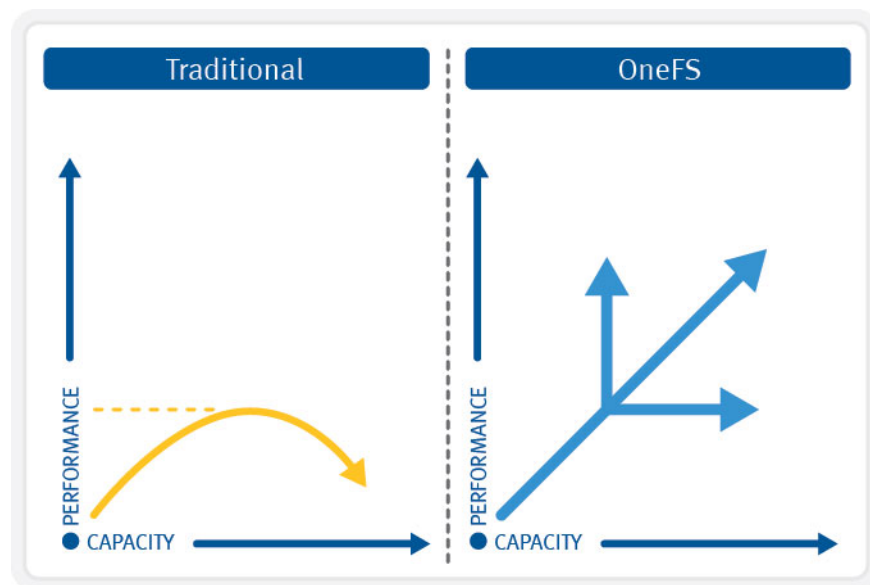

Scale capacity and performance linearly with OneFS

DATA PROTECTION FOR RESILIENCY AND HIGH AVAILABILITY

OneFS includes a core technology, FlexProtect[®], which utilizes Reed-Solomon encoding to provide redundancy and data availability. FlexProtect provides protection for up to four simultaneous failures of either full nodes or individual drives. This goes far beyond the maximum level of RAID commonly in use today, which is the double-failure protection of RAID 6.

Because the FlexProtect feature in OneFS is file aware, it also provides file-specific protection capabilities. An individual file or directory can be given a specific protection level, and different portions of the file system can be protected at levels aligned to the importance of the data or workflow. Critical data can be protected at a higher level, whereas less critical data can be protected at a lower level. This provides storage administrators with a very granular protection/capacity trade-off that can be adjusted dynamically as a cluster scales and a workflow ages.

FlexProtect has been enhanced with OneFS to provide additional levels of protection for large capacity drives to improve storage efficiency while protecting data from failures. In addition, automatic monitoring and alerting when storage protection levels fall below a specified threshold provides administrators increased peace of mind from under protected clusters. OneFS includes file blocking for increased security, SMB3 for improved reliability, and optimized SyncIQ data replication, and enterprise-grade event logging and alerting.

OneFS incorporates several strategies for data protection, including snapshots for backup and recovery, and data replication for disaster recovery protection. OneFS snapshots are highly scalable and typically take less than one second to create. They create little performance overhead, regardless of the level of activity of the file system, the size of the file system, or the size of the directory being copied. Also, only a file's

changed blocks are stored when updating the snapshots, which helps ensure highly efficient snapshot storage utilization.

OneFS, combined with Isilon SnapshotIQ™ software, can be used to create up to 1,024 snapshots per directory, thereby offering significantly improved recovery-point objective (RPO) timeframes. OneFS also provides near-immediate restoration of snapshot data backups to recover data quickly. With OneFS, snapshot restores are fast, efficient, and simple.

For your disaster recovery protection, OneFS and Isilon SyncIQ® software combine to deliver high-performance asynchronous replication of data that addresses a broad range of RPOs and recovery time objectives (RTOs). This solution is easily optimized for either LAN or WAN connectivity to replicate over short or long distances, thereby providing protection from both site-specific and regional disasters.

To reduce replication times between clusters and increase efficiency, OneFS combines with SyncIQ enable file splitting to allow large files to be partitioned across multiple threads and replicated in parallel. File sub-ranges can be divided and split across multiple threads resulting in shorter replication cycles.

OneFS further simplifies and accelerates disaster recovery and business continuity at scale with integrated and push-button simple failover and failback. With faster, easier failover and failback capabilities, most workflows will produce dramatic improvements in sync times. The same workflow will also be able to perform multiple syncs in the same time for “fresher” target data.

Each of these enhanced data protection capabilities will help you reduce both the RPO and RTO of mission-critical applications.

ROBUST SECURITY OPTIONS

To help you meet your corporate governance and compliance requirements, OneFS includes robust security options that offer unprecedented levels of scale-out NAS security.

OneFS and Isilon SmartLock® software combine to provide write once, read many (WORM) data protection, which prevents the accidental, premature, or malicious alteration or deletion of your critical data. With OneFS, we also help you meet regulatory and governance needs—including stringent SEC Rule 17a-4 requirements—by providing tamper-proof data retention and protection of your business-critical data. You can seamlessly failover and failback your compliance data with SyncIQ integration.

Isilon also includes a file system audit capability for SMB and NFS protocols to improve security and control of your storage infrastructure and address important regulatory and compliance requirements. With this audit capability, you will be able to determine which users are accessing specific files, and control and manage file access permissions more effectively. File System audit events can also be forwarded to syslog or the Dell EMC Common Event Enabler for filtering and analysis.

To further enhance security, OneFS incorporates roles-based administration control (RBAC) capabilities, which you can use to establish a secure role separation between storage administration and file system access, thereby preventing malicious or accidental changes to your data. With these capabilities, a web UI allows you to controls the creation, delegation, setting, and changing the roles and providing simplicity of operations. Administrators may also use this to determine permissions on a specific file or directory and provide enhanced troubleshooting capability.

OneFS also enables you to create authentication zones that provide secure, isolated storage pools for specific departments within your organization. This also allows you to consolidate storage resources for increased operational efficiency without compromising organizational security. With OneFS, access zones provide support for an HDFS namespace for each access zone. This means you can run multiple separate

HDFS namespaces in the same cluster. OneFS also introduces support for access zones for the NFS protocol.

OneFS further extends these robust security options with Security and Technical Implementation Guide (STIG) hardening, CAC/PIV Smartcard authentication, and FIPS OpenSSL support.

OneFS enables the use of Data-at-Rest Encryption (DARE) with industry-standard self-encrypting drives (SEDs) in Isilon nodes. DARE protects against drive theft or loss by keeping data encrypted on drives. OneFS enables data to be securely erased before drives are repurposed or retired by shredding encryption keys.

Cryptographic erasure to wipe data can be done in a matter of seconds. DARE also helps you address important data security regulatory requirements, including the Federal Information Security Management Act (FISMA).

HIGHLY VERSATILE STORAGE PLATFORM

OneFS is ideally suited for file-based, object-based and unstructured Big Data applications in enterprise environments—including large-scale home directories, file shares, archives, and business analytics—as well as a wide range of data-intensive, high-performance computing environments such as energy exploration, financial services, Internet and hosting services, engineering, manufacturing, media and entertainment, bioinformatics, and scientific research.

Isilon scale-out NAS, powered by OneFS, is the ideal storage platform to help you address the challenges and opportunities of unstructured data in your enterprise. The introduction of a new generation of Isilon hardware products consisting of six new platforms enable enterprises to consolidate a wide range of file workloads on Isilon. It includes: an all-flash platform, three hybrid platforms, and two archive platforms. All six new Isilon platforms are powered by Isilon OneFS 8.1 a new version of the Isilon operating system.

The new Isilon platforms all use a new, highly dense modular architecture that provides four Isilon nodes within a single 4U chassis. This new design provides significantly greater storage density and allows organizations to reduce data center space requirements and related costs by up to 75%. With this compact design, customers can easily scale performance and capacity by flexibly combining them in a single cluster. The nodes can seamlessly integrate with existing Isilon clusters and automatically tier data across all-flash, hybrid or archive nodes – and to the cloud - to optimize storage resources and lower costs

TAKE THE NEXT STEP

Contact your Dell EMC sales representative or authorized reseller to learn more about how Isilon scale-out NAS storage solutions can benefit your organization.

[Shop Dell EMC Isilon](#) to compare features and get more information.



Dell, EMC and other trademarks are trademarks of Dell Inc. or its subsidiaries.

© Copyright 2017 Dell Inc. All rights reserved. Published in the USA. 4/17 Data Sheet H10717.1

Dell EMC believes the information in this document is accurate as of its publication date. The information is subject to change without notice.