



AX4-5 Series

Fibre Channel Supported Configurations Overview

January 4, 2010

This document contains an overview of the configuration rules for AX4-5 series Fibre Channel storage systems.

Note: A "storage system" is called an "array" in the AX4-5 support matrix.

Topics include:

- ◆ Operating system support 2
- ◆ Path management support..... 2
- ◆ Hardware support..... 3
- ◆ Fibre Channel configuration rules 4
- ◆ Sample configurations 8
- ◆ NetWare support statement 19

Operating system support

The following operating systems are supported:

- ◆ AIX 5.2, 5.3, and 6.1
- ◆ HP-UX 11.11 and 11.23
- ◆ Linux:
 - RedHat 4.0 and 5.0
 - Novell SUSE 9 and 10
- ◆ NetWare - refer to the [“NetWare support statement”](#) on page 19
- ◆ Solaris 8 (SPARC), 9 (SPARC) and 10 (SPARC and x86)
- ◆ VMware ESX Server 3 and 3.5 and ESX Server 4
- ◆ Windows 2000
- ◆ Windows Server 2003
- ◆ Windows Server 2008

For details on operating system and cluster support, refer to the support matrix on the AX4-5 support website.

Path management support

A path is a connection between a host bus adapter (HBA) port and a target SP port in a storage system. Each HBA that is directly connected or zoned through a switch to an SP port is an initiator of that SP port. An HBA port can be zoned through different switch ports to the same SP port or to different SP ports, resulting in multiple paths between the HBA port and an SP.

For supported native path management or vendor path management software such as EMC[®] PowerPath[®] software, refer to the support matrix on the AX4-5 support website.

Hardware support

This section lists the hardware supported for AX4-5 environments.

Note: The minimum FLARE OE version for the AX4-5SCF4 and AX4-5F8 storage systems is 02.23.050.5.707.

Storage-system disk support

An AX4-5SC or AX4-SCF4 can have a maximum of 12 disks. An AX4-5 or AX4-5F8 *without* the expansion pack installed can have a maximum of 12 disks. An AX4-5 or AX4-5F8 *with* the expansion pack installed can have up to 4 disk-array enclosures (DAE-AXs) for a maximum of 60 disks. The disks can be SATA and/or SAS disks, provided disks 0-3 in the DPE-AX (the system disks) are either all SATA or all SAS disks.

Note: For an AX4-5SC or AX4-5 *without* the expansion pack installed and running FLARE OE version 02.23.050.5.5xx or lower, all the disks in the DPE-AX must be SATA disks.

Server hardware support

We support connection of the following vendors' servers to AX4-5 series storage systems:

- ◆ Bull
- ◆ Dell
- ◆ FSC
- ◆ HP
- ◆ IBM
- ◆ Intel
- ◆ NEC
- ◆ Sun

For additional hardware vendors and details about the supported server hardware, refer to the support matrix on the AX4-5 support website.

Fibre Channel host bus adapter (HBA) support

We support use of the following Fibre Channel HBAs with the AX4-5 series Fibre Channel storage systems:

- ◆ Emulex
- ◆ QLogic

For details on the support for these HBAs, refer to the support matrix on the AX4-5 support website.

Fibre Channel switch support

We support switches from the following vendors:

- ◆ Brocade
- ◆ Cisco

For details on the support for these switches, refer to the support matrix on the AX4-5 support website.

Fibre Channel configuration rules

When you set up a configuration with an AX4-5SC , AX4-5SCF4, AX4-5, or AX4-5F8, follow these rules:

- ◆ For an AX4-5SC or AX4-5SCF4, you can connect a maximum of 20 HBAs to the SP, and a maximum of 10 servers to the storage system.
- ◆ For an AX4-5 or AX4-5F8 *without* an expansion pack installed, you can connect a maximum of 10 HBAs to each SP, and a maximum of 10 servers to the storage system.
- ◆ For an AX4-5 or AX4-5F8 *with* an expansion pack installed, you can connect a maximum of 64 HBAs to each SP, and a maximum of 64 servers to the storage system.
- ◆ Do not use HBAs from different manufacturers in the same server, except in Solaris servers. For more information, refer to the support matrix on the AX4-5 support website.
- ◆ You can connect a server to a maximum of four storage systems. The Navisphere[®] management software (Navisphere Express or Navisphere Manager) must be the same for all storage systems

connected to the server. The same server can connect to an AX4-5 and also to AX series, CX4 series, CX3 series and/or CX series storage systems, *only if*:

- The server is running the Navisphere Host Agent and/or the Navisphere Server Utility version 6.26.5 or later for all but CX4 series and version 6.28 or later for CX4 series.
- The AX4-5 series and AX series storage systems are running Navisphere Manager.
- The master of the Navisphere domain with these storage systems is *one* of the following:
 - An AX4-5 storage system is running FLARE OE version 02.23.050.5.5xx or later
 - A CX4 series storage system
 - A CX3 series storage system running FLARE OE version 03.26.xxx.5.014 or later
 - A CX series storage system running FLARE OE version 02.24.xxx.5.018 or later
 - A Navisphere off-array management station running the Navisphere UIs version 6.26.21.051 or later for all but CX4 series and version 6.28 or later for CX4 series
- ◆ You can create a maximum of 512 virtual disks per storage system.
- ◆ You must connect a server to a storage system either directly or through a switch. You cannot connect a server to the *same* storage system both directly and through a switch.
- ◆ You can install all direct connect configurations. [Figure 1](#) and [Figure 7](#) illustrate direct connect configurations.
- ◆ You can install switches from Brocade and QLogic if you use their zoning wizards.
- ◆ Do not mix switches from different manufacturers in the same storage area network (SAN).
- ◆ An authorized service provider must install any switch configuration that uses an interswitch link (ISL). We do not support the connection of more than two switches with an ISL. [Figure 14](#) illustrates a switch configuration that use an ISL
- ◆ In any supported multiple-server configuration, the servers can run the same operating system or any combination of supported operating systems.

- ◆ The snapshot feature requires that the secondary server not be the source server. As a result, the snapshot feature is not supported for the configurations shown in [Figure 3](#) and [Figure 4](#).
- ◆ You must install supported path management software on all servers connected to a storage system in any configuration.
- ◆ A clustered configuration can have two to eight nodes.
- ◆ All nodes in a cluster configuration must run the same operating system. The figures in the “[Sample configurations](#)” section may show other operating systems, but dissimilar operating systems cannot be clustered.
- ◆ You must connect all nodes in a cluster configuration to the same SPs.
- ◆ The installation of an operating system on a storage system for the purpose of booting the server from the storage system is not a user installable option.
- ◆ Booting from a storage system on clustered servers running Windows 2000 requires a dedicated boot HBA.
- ◆ Booting from a storage system on clustered servers running Windows Server 2003 *does not* require a dedicated boot HBA.

Backup device support

EMC has tested and qualified only storage area network (SAN) attached backup devices. SAN-attached backup configurations include a backup device connected to a port on the switch. These configurations are not currently customer installable. For supported SAN-attached backup configurations, refer to the support matrix on the AX4-5 support website.

For tape devices connected directly to a backup host, EMC strongly recommends that you review the component vendor's information on supported configurations. Refer to the backup host vendor's information for host compatibility with the SCSI or Fibre Channel interface that connects the host to the tape drive. Refer to the tape device vendor's information for tape device compatibility with the SCSI or Fibre Channel interface. Refer to the backup software vendor's information for backup software compatibility with the tape device.

Remote replication

You can use the AX4-5 series storage systems with other CLARiiON® storage systems running EMC SAN Copy™ software to replicate data to and from the AX4-5 series storage system with Navisphere management software. For example, an AX4-5 series storage system connected to CX3 series or CX series storage system running SAN Copy can replicate data from branch offices back to the data center to provide disaster recovery protection and to consolidate the backup process. AX4-5 series storage systems can connect to CX3 series or CX series storage systems running SAN Copy through the supported switches listed in the support matrix on the AX4-5 support website.

AX4-5 EMC partners

EMC has a wide variety of distribution partners that offer the AX4-5 series storage systems. The information in this document contains supported components that are standard across our AX4-5 series of product solutions. EMC's AX4-5 partners offer a wider variety of the AX4-5 series solutions to fit your business needs. For a complete listing of current EMC distribution partners and their AX4-5 specific solutions, please refer to the EMC website with direct links to these partners. The specific link to this EMC site is:

<http://www.emc.com/partnersalliances/index.jsp>

Sample configurations

This section contains illustrations and descriptions of sample configurations. These illustrations show storage systems with two Fibre Channel ports per SP. The AX4-5SCF4 and AX4-5F8 storage systems have 4 Fibre Channel ports per SP.

Figure 1 shows a configuration that is not highly available. Two single points of failure are the HBA and SP. PowerPath on the server tells you if the path failed.

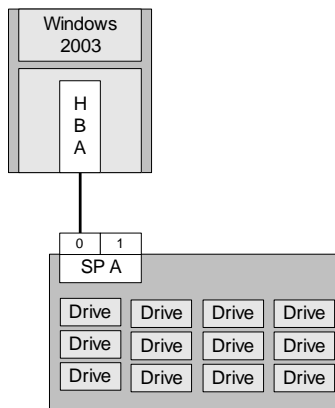

Figure 1 A server with a single HBA connected to one port of the SP

Figure 2 shows a configuration that is not highly available, but that gives two servers access to the storage system. Two single points of failure are the HBA and SP. PowerPath on each server tells you only if that one path has failed.

If the servers are running the same operating system, they can be clustered.

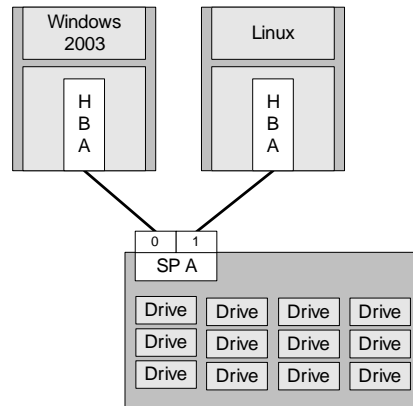

Figure 2 Two servers each with a single HBA connected to different ports on the same SP

Figure 3 shows a highly available configuration with one path to each SP. With PowerPath running on the server, the server can reach any virtual disk if one SP or one HBA fails.

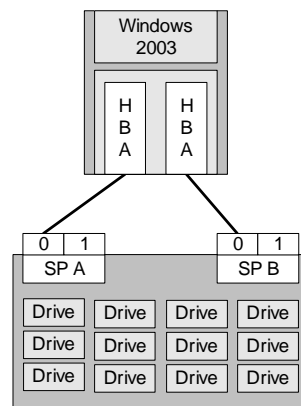

Figure 3 One server with two HBAs connected to a port on each SP

Figure 4 shows a highly available configuration with two paths to each SP (multipath). With PowerPath running on the server, the server can reach any virtual disk if one SP fails or if up to three HBAs fail.

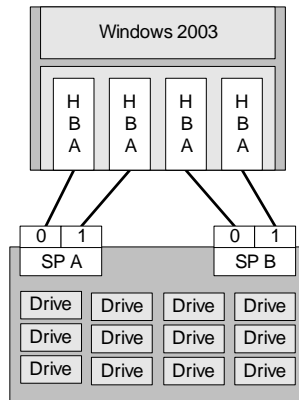

Figure 4 One server with four HBAs connected to an SP port on both SPs

Figure 5 shows a configuration that is not highly available. PowerPath running on the server tells you if the path has failed.

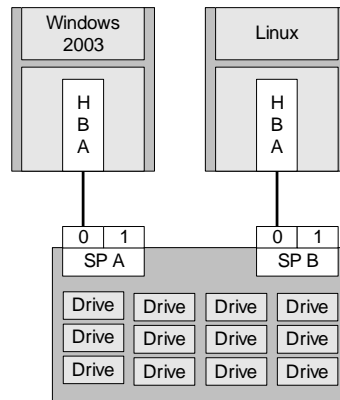

Figure 5 Two servers each with one HBA connected to an SP port on one SP

Figure 6 shows a configuration that is not highly available, but does provide four servers with access to the storage system. Each server has only one path to an SP. PowerPath running on the server tells you if one path has failed.

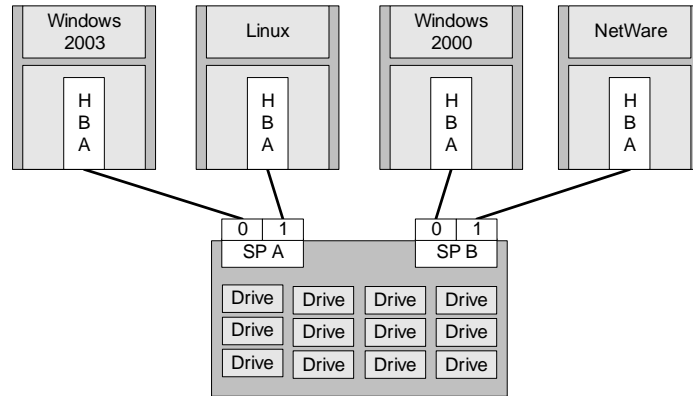

Figure 6 Four servers each with one HBA connected to an SP port on one SP

Figure 7 shows a highly available configuration where each server has one path to each SP. With PowerPath running on the server, the server can reach any virtual disk if one SP or one HBA fails.

If the servers are running the same operating system, they can be clustered.

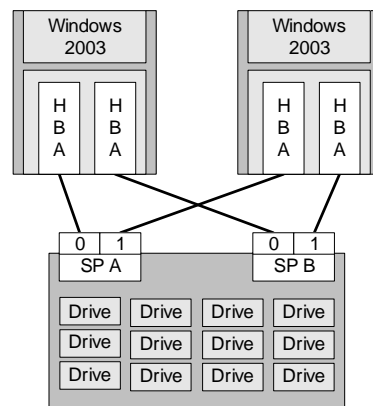

Figure 7 Two servers each with two HBAs connected to an SP port on both SPs

Figure 8 shows a configuration that can support up to six servers, each with one HBA. Each server can reach a port on either SP (see switch zoning explanation below). The server cannot access the storage system if its HBA fails or if the switch port it connects to fails. With PowerPath running on the server, the server can reach any virtual disk if one SP fails.

If the servers are running the same operating system, they can be clustered.

The switch is zoned so that an SP port connected to a switch port can reach each HBA connected to a switch port.

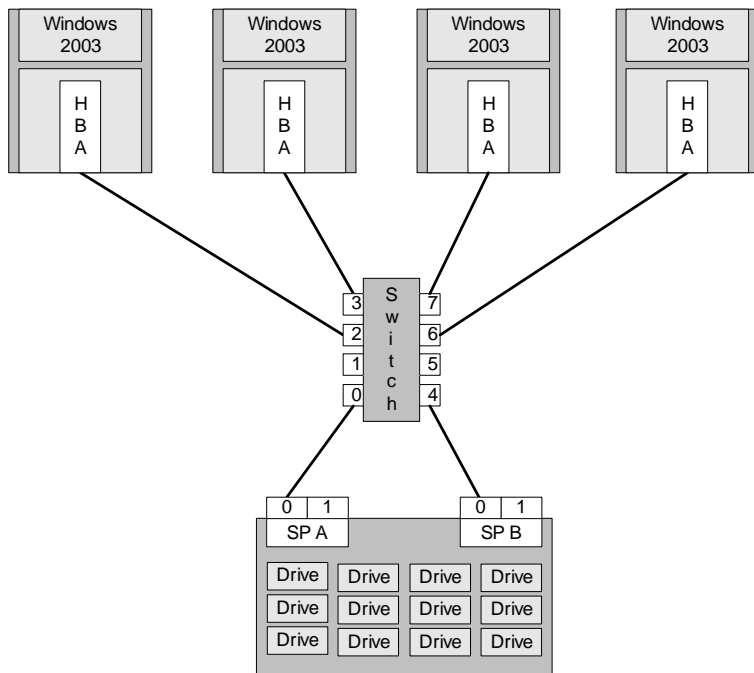

Figure 8 SAN with one switch and four servers each with one HBA

Figure 9 shows a configuration that is more highly available than the configuration in Figure 8 because each server has one path to each SP (see the zoning explanation below). The switch is a single point of failure. With PowerPath running on the server, the server can reach any virtual disk if one SP or one HBA fails.

If the servers are running the same operating system, they can be clustered.

The switch is zoned so that an SP port connected to a switch port can reach each HBA connected to a switch port.

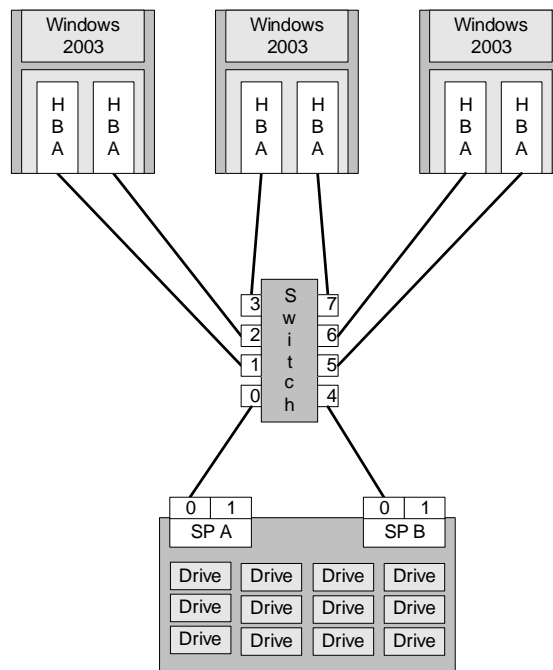

Figure 9 SAN with one switch and three servers each with two HBAs that can reach one SP port on both SPs

Figure 10 shows a highly available configuration where each server, which is connected to the switch, has one path to each SP (see the zoning explanation below). With PowerPath running on the server, the server can reach any virtual disk if one SP or one HBA fails.

An additional fourth server with two HBAs is directly connected to each SP on the storage system. Since all available ports on the switch are occupied, this configuration allows maximum server utilization.

The switch is zoned so that an SP port connected to a switch port can reach each HBA connected to a switch port.

If the servers are running the same operating system, they can be clustered.

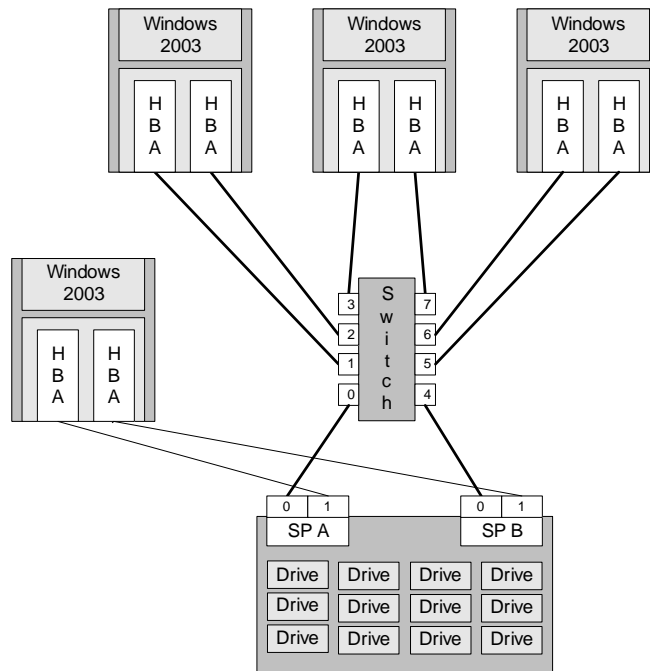

Figure 10 SAN with four servers each with two HBAs that can reach one SP port on both SPs

Figure 11 shows a highly available configuration that can support up to six servers, each with two HBAs. Each server has one path to each SP (see the zoning explanation below). With PowerPath running on the server, the server can reach any virtual disk if one SP or one HBA fails.

You can also connect the remaining SP ports A1 and B1 to port 4 on each switch to create more high availability. Each server will still be able to reach virtual disks if a switch fails because both SPs are connected to different switches. Also, if a server with a single HBA is connected to one of the switches, it will have access to both SPs.

Each switch is zoned so that an SP port connected to a switch port can reach each HBA connected to a switch port.

If servers are running the same operating system, they can be clustered.

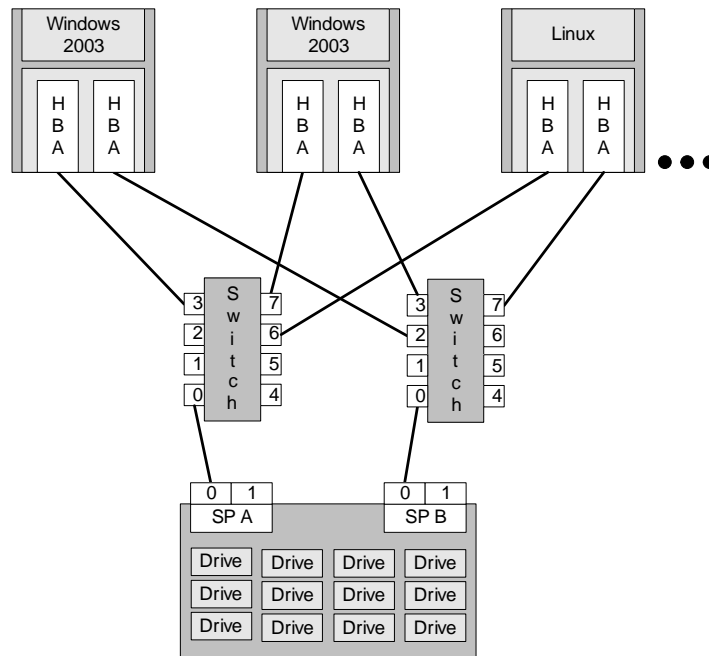

Figure 11 SAN with two switches and four servers

Figure 12 shows a non-highly available configuration that can support the maximum number of servers (8) that you can connect to the storage system. Each server has one path to each SP (see the zoning explanation below). With PowerPath running on the server, the server can reach any virtual disk if one SP fails. Although each server has one path to each SP, the server cannot access the storage system if its HBA fails or if the switch port it connects to fails.

If servers are running the same operating system, they can be clustered.

Each switch is zoned so that an SP port connected to a switch port can reach each HBA connected to a switch port.

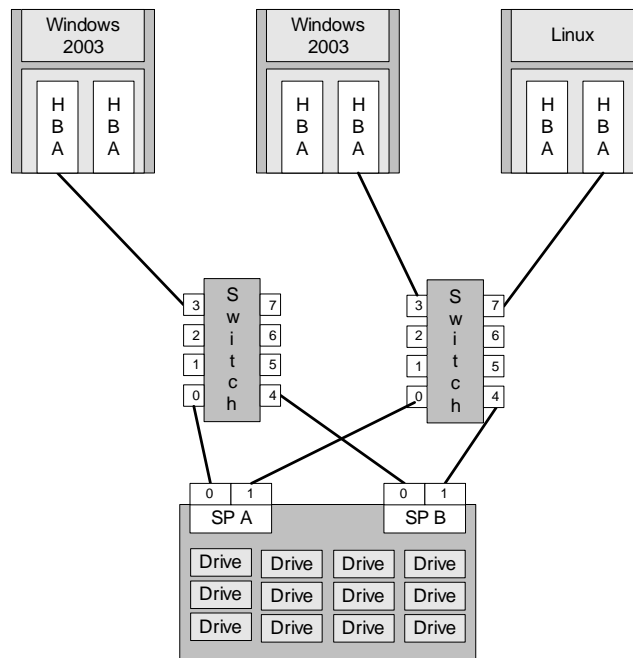

Figure 12 SAN with two switches and three servers each with two HBAs

Figure 13 shows a highly available configuration where each server has two paths to each SP (see the zoning explanation below). With PowerPath running on the server, the server can reach any virtual disk if one SP or one HBA fails. In addition, with redundant switches, each server can still reach virtual disks if a switch fails since both SPs are connected to both switches.

Each switch is zoned so that an SP port connected to a switch port can reach each HBA connected to a switch port.

If any servers are running the same operating system, they can be clustered.

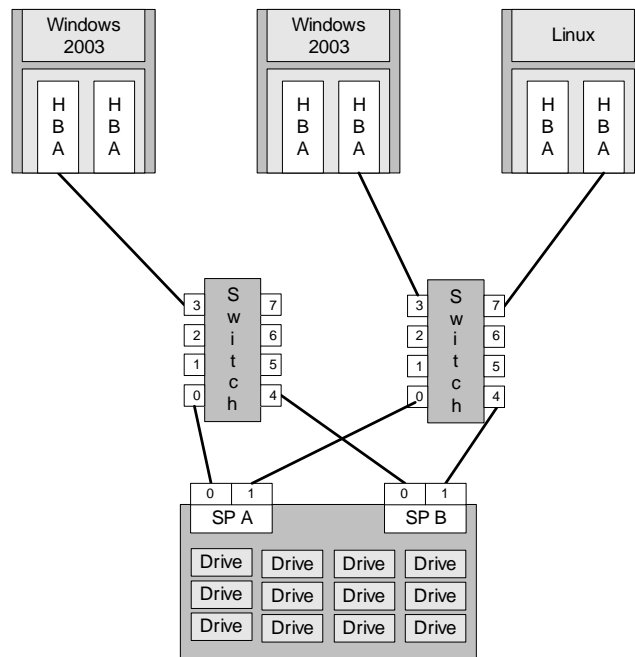

Figure 13 SAN with three servers each with two HBAs that can reach both SP ports on both SPs

Figure 14 shows a highly available configuration with the maximum number (4) of storage systems connected to the server. The server can reach each SP (see the zoning explanation below) through more than one path because of the interswitch links on ports 7-6 and 5-4. With PowerPath running on the server, the server can reach any virtual disk if a storage system's SP fails or if fewer than four HBAs fail.

Each switch is zoned so that an SP port connected to a port on either switch can reach each HBA connected to a port on either switch.

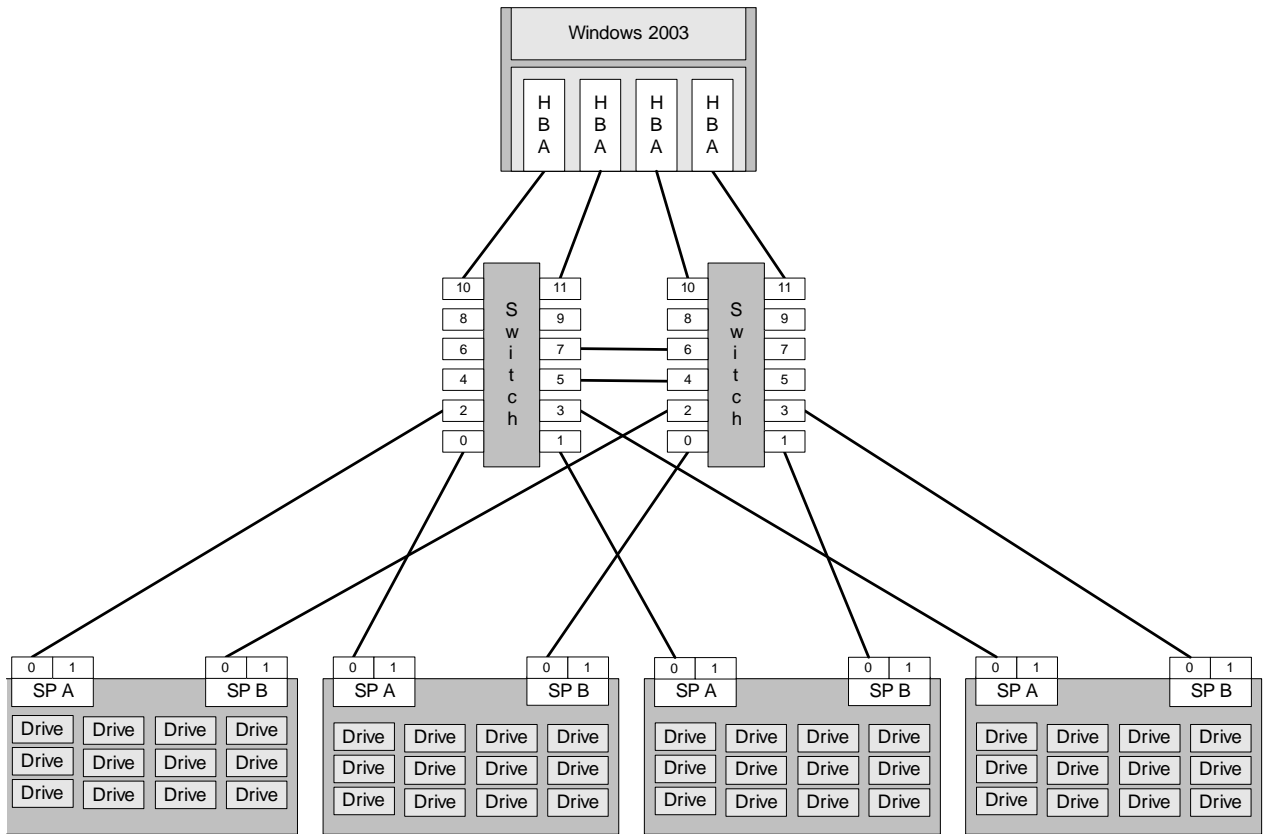

Figure 14 One server with four HBAs and four storage systems

NetWare support statement

This statement provides a mechanism for customers to run Novell NetWare according to the conditions outlined below. As part of this support provided by EMC, the customer agrees to the following terms:

- ◆ Any deviation from the configuration specified invalidates this support statement.
- ◆ EMC agrees to provide support only for the CLARiiON AX4-5 series storage systems
- ◆ EMC will provide its best effort to assist in escalation to Novell and/or QLogic

Note: Novell's NetWare strategy is to encourage their customers to migrate to Open Enterprise Server (OES), a SuSE SLES based platform that offers support for NetWare services as well as Linux. EMC will follow Novell's lead and limit future qualifications to OES platforms with new storage systems. EMC also reserves the right to change its support position as required. This support statement is valid for a period no later than the Novell published General End of Support Life for Novell NetWare 6.5.

Supported servers

The supported servers are all servers defined by Novell as supported with the NetWare versions listed in this support statement, supported by the specific server vendor and listed as supported for Windows and Linux in the *EMC Support Matrix*.

Supported HBA and driver

- ◆ QLogic HBA QLA2340, QLA2342, QLE2460, QLE2462, QLA2460, QLA2462, QLE2362 as supported by the specific server vendor and listed as supported for Windows and Linux in the *EMC Support Matrix*.
- ◆ Driver v6.90-O (letter O not zero) (requires manual host registration).

Supported operating system

- ◆ Novell NetWare 6.5 SP4, SP5, SP6, and SP7
- ◆ Novell Cluster Service 1.8.x (requires redundant HBA ports)
- ◆ Maximum of 16 cluster nodes

Supported storage systems

- ◆ AX4-5
- ◆ FLARE version 23
- ◆ Fibre Channel connections only

EMC software

- ◆ PowerPath 3.0.6 Hot Fix 1
- ◆ The host agent is not supported for registration. Manual registration is required on the storage system for NetWare hosts.
- ◆ The use of the version 6.19 NetWare Navisphere CLI client is not supported with AX4-5 series storage systems.
- ◆ For information regarding EMC CLARiiON layered applications support, see EMC Primus case # EMC176963.

Fibre Channel switch

Approved Fibre Channel switches are listed in the *EMC Support Matrix* with required Fibre Channel HBAs set as noted above.

Copyright © 2008-2010 EMC Corporation. All rights reserved.

EMC believes the information in this publication is accurate as of its publication date. The information is subject to change without notice.

THE INFORMATION IN THIS PUBLICATION IS PROVIDED "AS IS." EMC CORPORATION MAKES NO REPRESENTATIONS OR WARRANTIES OF ANY KIND WITH RESPECT TO THE INFORMATION IN THIS PUBLICATION, AND SPECIFICALLY DISCLAIMS IMPLIED WARRANTIES OF MERCHANTABILITY OR FITNESS FOR A PARTICULAR PURPOSE.

Use, copying, and distribution of any EMC software described in this publication requires an applicable software license.

For the most up-to-date regulatory document for your product line, go to the Technical Documentation and Advisories section on EMC Powerlink.

For the most up-to-date listing of EMC product names, see EMC Corporation Trademarks on EMC.com.

All other trademarks used herein are the property of their respective owners.