



Efficiency. Control. Choice.

# Vblock™ 0 Reference Architecture

## Introduction

### Goal of This Document

Vblock™ Infrastructure Packages (hereafter referred to in this document as Vblock) refers to these categories of solution offerings:

- Vblock 2—Vblock 2 delivers high-performance, large-scale virtualization across data centers of large enterprise customers. It includes Cisco® Unified Computing System™ (UCS), EMC® Symmetrix® VMAX™, and VMware® vSphere 4™ and can include flash technology to meet the high-performance demands of mission-critical applications.
- Vblock 1—Vblock 1 delivers performance and virtualization for large or mid-sized companies and is suitable for data centers of any size, including remote-office locations. It includes Cisco Unified Computing System, EMC CLARiiON® CX4 or EMC Celerra® Unified Storage, and VMware vSphere 4.
- Vblock 0—Vblock 0 is an ideal platform for companies that are in search of an entry-level configuration for small data centers, remote locations, or as a test/development platform. It includes Cisco Unified Computing System, EMC Celerra Unified Storage, and VMware vSphere 4.

This document describes and provides high-level design considerations for deploying Vblock 0.

### Audience

The target audience for this document includes sales engineers, field consultants, advanced services specialists, and customers who want to deploy a virtualized infrastructure using VMware vSphere/vCenter on Cisco UCS connected to EMC Celerra storage products. The document also explores potential business benefits of interest to senior executives.

## Objectives

This document is intended to describe:

- The role of Vblock Infrastructure Packages within a data center
- The capabilities and benefits of Vblock Infrastructure Packages
- The components of Vblock Infrastructure Packages

This document also highlights the collaborative efforts of three partner companies—Cisco and EMC with VMware—working together on a common goal of providing proven technology to customers.

## Vblock Infrastructure Packages Overview

IT is undergoing a transformation. The current “accidental architecture” in the data center increases procurement time, management costs, and complexity while making it difficult to meet customer service level agreements (SLAs). This makes it difficult for IT to respond to the needs of the business in a timely manner and creates the perception of IT being a cost center. The data center is now moving towards a “private cloud” model, which is a new model for delivering IT as a service, whether that service is provided internally (IT today), externally (service provider), or in combination. This new model requires a new way of thinking about both the underlying technology and the delivery model for customer success.

While the need for a new model has never been more clear, navigating the path to that model has never been more complicated. The benefits of private clouds are capturing the collective imagination of the business in organizations of all sizes around the world. The realities of outdated technologies, rampant incremental approaches, and the absence of a compelling end-state architecture are impeding adoption by customers.

By harnessing the power of virtualization, private clouds place considerable business benefits within reach. These include:

- Business enablement—Increased business agility and responsiveness to changing priorities; speed of deployment and the ability to address the scale of global operations with business innovation
- Service-based business models—Ability to operate IT as a service
- Facilities optimization—Lower energy usage; better (less) use of data center real estate
- IT budget savings—Efficient use of resources through consolidation and simplification
- Reduction in complexity—Moving away from fragmented, “accidental architectures” to integrated, optimized technology that lowers risk, increases speed, and produces predictable outcomes
- Flexibility—Ability of IT to gain responsiveness and scalability through federation to cloud service providers while maintaining enterprise-required policy and control

Moore’s Law (1965) was, in the 1980s and 1990s, replaced by the unwritten rule that everyone knew and did not lament loudly enough: enterprise IT doubles in complexity and total cost of ownership (TCO) every five years and IT gets more pinched by the pressure points.

Enterprise IT solutions over the past 30 years have become more costly to analyze and design, procure, customize, integrate, inter-operate, scale, service, and maintain. This is due to the inherent complexity in each of these lifecycle stages of the various solutions.

Within the last decade, we have seen the rise of diverse inter-networks—variously called “fabrics,” “grids,” and, generically, the “cloud”—constructed on commodity hardware, heavily yet selectively service-oriented with a scale of virtualized power never before contemplated, housed in massive data centers on- and off-premises.

Yet amid the buzzword din—onshoring/offshoring, in-/out-/co-sourcing, blades and RAIDs, LANs and storage area networks (SANs), massive scale and hand-held computing—virtualization (an abiding computing capacity since early mainframe days) has met secure networking (around since ARPANet), both perfected, to form the basis for the next wave, rightly delineated.

It has only been in the past several years that the notion of “cloud computing”—infrastructure, software, or whatever-business-needs as an IT service—has been taken seriously in its own right, championed by pioneers who have proved the model’s viability even if on too limited a basis.

With enterprise-level credibility, enabled by the best players in the IT industry, the next wave of computing will be ushered in on terms that make business sense to the business savvy.

## What Constitutes Vblock Infrastructure Packages?

Vblock Infrastructure Packages are pre-engineered, tested, and validated units of IT infrastructure that have a defined performance, capacity, and availability SLA. The promise that Vblock Infrastructure Packages offer is to deliver IT infrastructure in a new way and accelerate organizations’ migration to private clouds.

Vblock Infrastructure Packages grew out of an idea to simplify IT infrastructure acquisition, deployment, and operations. Removing choice is part of that simplification process. To that end, many decisions regarding current form factors may limit the scope to customize or remove components. For example, substituting components is not permitted as it breaks the tested and validated principle. While Vblock Infrastructure Packages are tightly defined to meet specific performance and availability bounds, their value lies in a combination of efficiency, control, and choice. Another guiding principle of Vblock Infrastructure Packages is the ability to expand the capacity of Vblock Infrastructure Packages as the architecture is very flexible and extensible. The following sections provide definitions for Vblock Infrastructure Packages configurations with mandatory, recommended, and optional hardware and software.

## Vblock Infrastructure Packages—A New Way of Delivering IT to Business

Vblock Infrastructure Packages accelerate infrastructure virtualization and private cloud adoption:

- Production-ready
  - Integrated and tested units of virtualized infrastructure
  - Best-of-breed virtualization, network, compute, storage, security, and management products
- SLA-driven
  - Predictable performance and operational characteristics
- Reduced risk and compliance
  - Tested and validated solution with unified support and end-to-end vendor accountability

Customer benefits include:

- Simplifies expansion and scaling
- Add storage or compute capacity as required
- Can connect to existing LAN switching infrastructure
- Graceful, non-disruptive expansion
- Enables introduction of Fibre Channel over IP (FCIP), Storage Media Encryption (SME), and so on, later for Multi-pod

- Enables scaling to multi-Vblock Infrastructure Packages and multi-data center architectures
- Multi-tenant administration, role-based security, and strong user authentication

## Vblock Infrastructure Packages Design Principles

A data center is a collection of pooled Vblock Infrastructure Packages aggregated in “Zones.” Zones have the following characteristics:

- A unit of assembly that provides a set of services, at a known level, to target consumers
- Self-contained, but it may also use external shared services
- Optimized for the classes of services it is designed to provide
- Can be clustered to provide availability or aggregated for scalability, but Vblock Infrastructure Packages are each still viable on their own
- Fault and service isolation—The failure of one or more Vblock Infrastructure Packages will not impact the operation of other Vblock Infrastructure Packages (service level degradation may occur unless availability or continuity services are present)

Vblock Infrastructure Packages are architectures that are pre-tested, fully-integrated, and scalable. They are characterized by:

- Repeatable “units” of construction based on “matched” performance, operational characteristics, and discrete of power, space, and cooling
- Repeatable design patterns facilitate rapid deployment, integration, and scalability
- Being designed from the “Facilities to the Workload” to be scaled for the highest efficiencies in virtualization and workload re-platforming
- An extensible management and orchestration model based on industry-standard tools, APIs, and methods
- Being built to contain, manage, and mitigate failure scenarios in hardware and software environments

Vblock Infrastructure Packages offer deterministic performance and a predictable architecture:

- Predictable SLA—Granular SLA measurement and assurance
- Deterministic space and weight—Floor tiles become unit of capacity planning
- Power and cooling—Consistent power consumption and cooling (KWh/BTUs) per unit
- Pre-determined capacity and scalability—Uniform workload distribution and mobility
- Deterministic fault and security isolation

Vblock Infrastructure Packages benefits include:

- Acceleration of the journey to pervasive virtualization and private cloud computing while lowering risk and operating expenses
- Ensuring security and minimize risk with certification paths
- SLA support and management
  - Resource metering and reporting
  - Configuration and provisioning
  - Resource utilization
- Validated platforms that enable seamless extension of the environment

- O/S and application support:
  - Vblock Infrastructure Packages accelerate virtualization of applications by standardizing IT infrastructure and IT processes
  - Broad range of O/S support
  - All current applications that work in a VMware environment also work in a Vblock Infrastructure Packages environment
  - Vblock Infrastructure Packages validated applications include SAP, VMware View 4, and Web applications.

Vblock Infrastructure Packages are scalable platforms for building solutions:

- Modular architecture enables graceful scaling of Vblock Infrastructure Packages environments
- Consistent policy enforcement and IT operational processes
- Add capacity to one or more existing Vblock Infrastructure Packages or add more Vblock Infrastructure Packages
- Mix-and-match Vblock Infrastructure Packages to meet specific application needs

## Vblock 0 Architecture Components

[Figure 1](#) provides a high-level overview of the components in the Vblock 0 architecture<sup>1</sup>.

1. The network layer represented in [Figure 1](#) by the Cisco Nexus<sup>®</sup> 7000 is not a Vblock Infrastructure Packages component. EMC Ionix<sup>™</sup> is optional and available at additional cost.

Figure 1 Vblock 0 Architecture Components

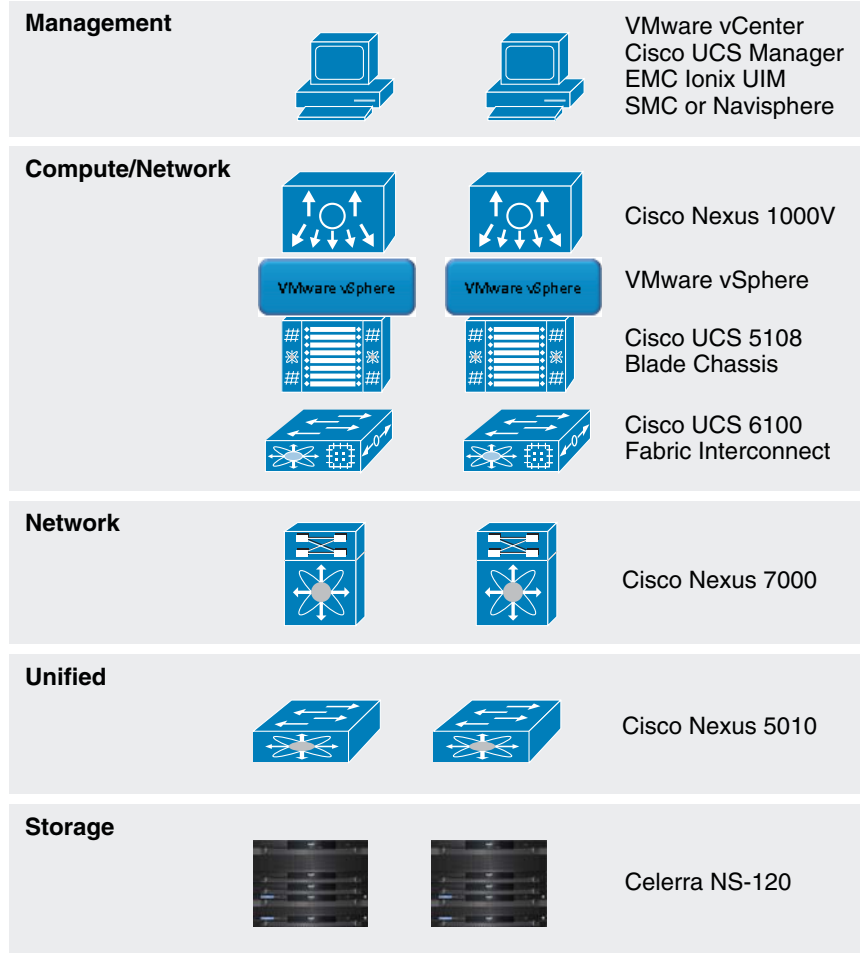

228915

## Vblock 0 Components

Vblock 0 is an ideal platform for companies that are in search of an entry-level configuration for small data centers, remote locations, or as a test/development platform. It includes Cisco Unified Computing System, EMC Celerra Unified Storage, and VMware vSphere 4.

Vblock 0 components:

- Compute
  - 4-16 Cisco UCS B-series half-slot blade servers (3-15 blade servers for workload, 1 blade server for management)
- Network
  - Cisco Nexus 1000V
  - The UCS uses 6100 series fabric interconnects that carry the network and storage (IP-based) traffic from the blade servers to the connected LAN
- Storage
  - Single or dual EMC Celerra NS-120s in a single rack with storage scaling from 2 DAEs to 46 TB

- VMware vSphere with ESXi 4.0/vCenter 4.0 update 1<sup>1</sup>
- Management
  - EMC Ionix Unified Infrastructure Manager (optional)
  - VMware vCenter
  - EMC PowerPath<sup>®</sup>/VE
  - Cisco UCS Manager

## Vblock 0 Design and Configuration Details

Figure 2 provides a high-level topological view of the components of Vblock 0.

**Figure 2 High-Level Topological View of Vblock 0**

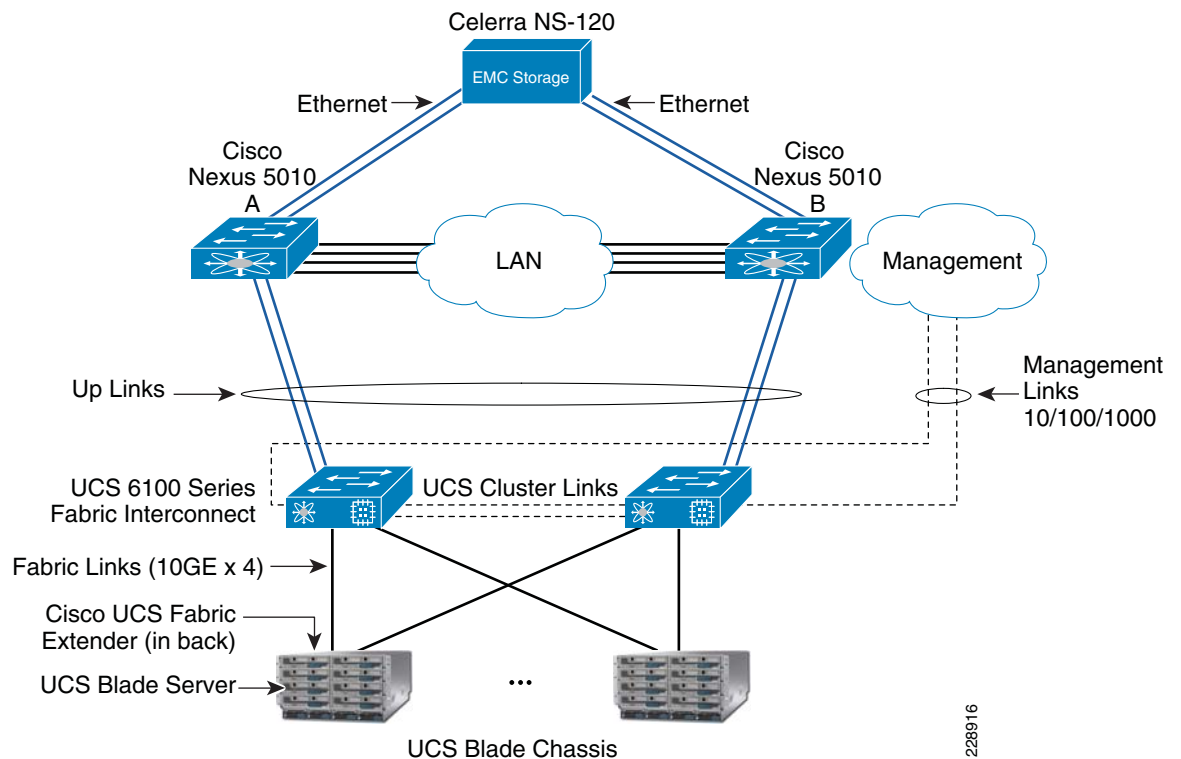

Vblock Infrastructure Packages consist of a minimum and maximum amount of components that offer balanced I/O, bandwidth, and storage capacity relative to the compute and storage arrays offered. Vblock Infrastructure Packages are fully-redundant autonomous systems that have 1+1 or N+1 redundancy by default.

In Vblock 0, each of the two UCS chassis contains a minimum of four and a maximum of 16 B-200 blade servers, each with 48 GB RAM.

1. VMware vSphere 4 Enterprise Plus Suite is the licensed software.

The amount of RAM per blade server within a Vblock 0 may be adjusted if you have specific requirements within the definition of a Vblock Infrastructure Package. For example, if you have specific needs to have a mixture of RAM densities, you can specify 48 GB, 72 GB, and 96 GB RAM options. This however requires careful consideration of the operational environment and introduces some variance.

For Vblock 0, each B-200 series blade server module has 72 GB SATA drives for ESXi local boot service and local page memory purposes.

The Cisco Nexus 5010 provides 10 Gb Ethernet connectivity between the UCS Fabric Interconnect and 1 Gb Ethernet connectivity between the Celerra NS-120 Data Mover ports.

[Figure 3](#) illustrates the interconnection of the Cisco Nexus 5010 in Vblock 0. For more information on the Cisco Nexus 5010, see [Cisco Nexus 5010](#).

VMware vSphere 4 Enterprise Plus and Cisco Nexus 1000V licenses are mandatory within all Vblock Infrastructure Packages included within the defined bill-of-materials. It should be noted that other hypervisors are not supported by Vblock Infrastructure Packages and invalidate the Vblock Infrastructure Packages support agreement.

Cisco Nexus 1000V and Enterprise Plus are mandatory components due to the inherent richness that they offer in terms of policy control, segmentation, flexibility, and instrumentation.

## Networking

Vblock 0 introduces the use of a Cisco Nexus 5010 to provide 10 Gb Ethernet connectivity to connect the UCS Fabric Interconnect and 1 Gb to the Celerra NS-120 Data Mover ports.

For upstream connectivity, the UCS 61x0 are connected using either 4\*10GE/Unified Fabric or 8\*10GE/Unified Fabric connections. A Nexus 5010 may optionally be deployed if local connections are required for the Celerra NS-120(s), or if Fibre Channel Connectivity is required.

By default, all connectivity is handled over IP switches and served through iSCSI, CIFS, or NFS to the respective host systems.

[Figure 3](#) illustrates the interconnection of the Cisco Nexus 5010s in Vblock 0.

For more information, see [NFS Datastores and Native File Services—EMC Celerra](#).

## Storage

Storage capacity has been tuned to match the I/O performance of the attached UCS systems. Additionally, some analysis of the likely underlying applications has also been taken into account to characterize user or VM densities that are likely for a given Vblock Infrastructure Package. Obviously, these numbers are highly variable based upon your use cases and requirements; the numbers are intended to provide guidance on typical densities.

[Figure 3](#) illustrates the EMC Celerra NS-120 and dual Celerra NS-120 configurations and interconnections to the switches and UCS chassis.

**Figure 3** EMC Celerra NS-120 in Vblock 0

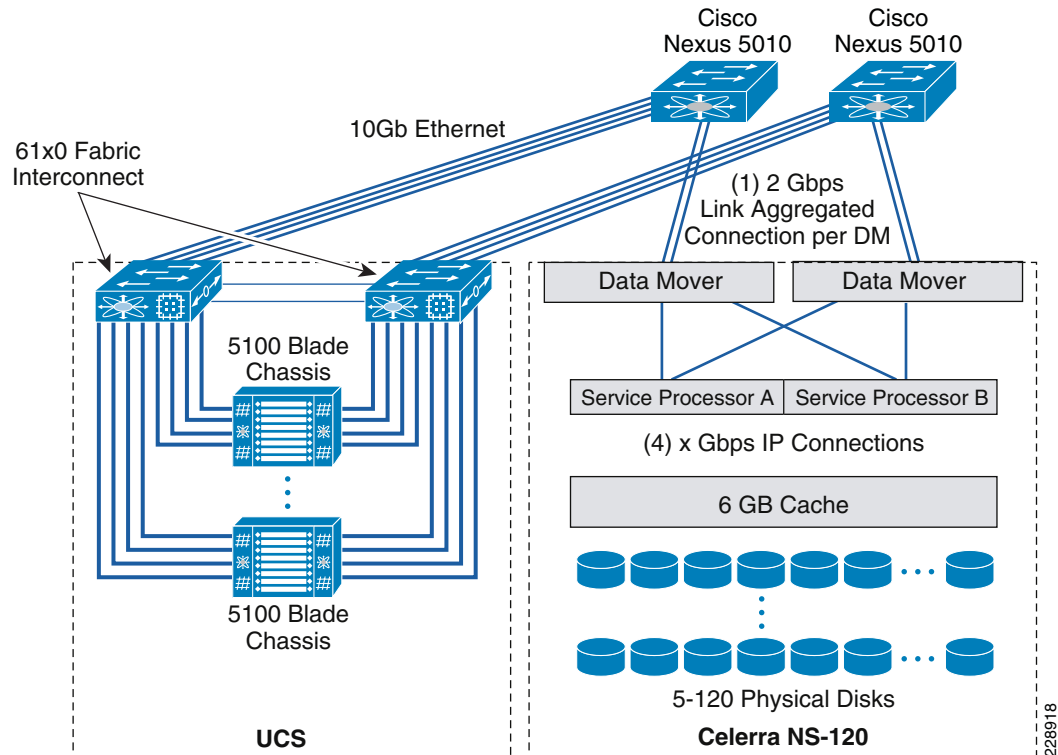

The Celerra system is configured with SATA drives with N+1 spares redundancy. This means that although the minimum Vblock 0 storage is two trays and 8 TB, it can scale up to 42+ TB using DAE expansion shelves.

Within the Vblock Infrastructure Packages definitions, network-attached storage (NAS) access is recommended for vSphere. The EMC Celerra NS-120 offers iSCSI and NFS for vSphere applications and CIFS protocol support for Windows applications in the environment. It should be noted that UCS does not currently support iSCSI boot of physical servers (VMs can boot on iSCSI through vSphere).

Vblock 0 deployments offer boot from local disk within the UCS and the use of iSCSI and NFS for the creation of datastores internally within vSphere deployments.

EMC PowerPath/VE (PP/VE) provides several benefits in terms of performance, availability, and operations, so the base PP/VE license is mandatory for Vblock 0.

For more information on the EMC Celerra storage system, see:  
<http://www.emc.com/products/family/celerra-family.htm>.

## Vblock Infrastructure Packages Management

Within the Vblock Infrastructure Packages there are several managed elements, some of which are managed by their respective element managers. These elements offer corresponding interfaces that provide an extensible, open management framework. The Vblock Infrastructure Packages management framework showing relationships and interfaces is shown in [Figure 4](#). The individual element managers and managed components are:

- VMware vCenter Server
- Cisco UCS Manager

- EMC Celerra Manager

A Vblock Infrastructure Packages element manager, Unified Infrastructure Manager (UIM)<sup>1</sup>, manages the configuration, provisioning, and compliance of individual Vblock Infrastructure Packages and multiple mixed Vblock Infrastructure Packages. This accrues several benefits as it provides a “single pane of glass” for systems configuration and integration and provides Vblock Infrastructure Packages service catalogs and Vblock Infrastructure Packages self-service portal capabilities.

**Figure 4 Vblock Infrastructure Packages Management**

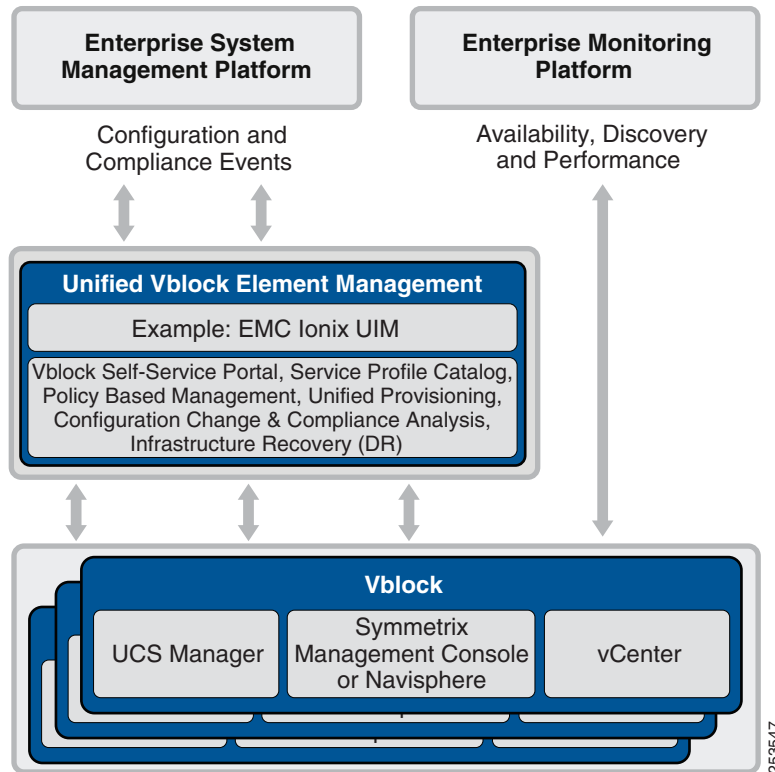

It should be noted that Ionix UIM does not provide fault, performance monitoring, billing capabilities, or software lifecycle management capabilities. By the abstractions offered by UIM, and using UIM as a single point of integration, this simplifies Vblock Infrastructure Packages integration into IT service catalogs and workflow engines. In this respect, UIM can dramatically simplify Vblock Infrastructure Packages deployment by abstracting the overall provisioning aspects of Vblock Infrastructure Packages, while offering granular access to individual components for troubleshooting and fault management.

It should be noted however that Vblock Infrastructure Packages have an open management framework that allows an organization to integrate Vblock Infrastructure Packages management with their choice of management tools should they so desire.

## Vblock Infrastructure Packages Qualification of Existing Environments

Many organizations have extensive EMC and VMware components within their data centers. However, simply adding a UCS system to this environment does not constitute a Vblock from a number of aspects, including:

- Do the existing arrays meet the published system capacity for Vblock 0?
  1. Optional and available at additional cost.

- What firmware/software versions are running within the infrastructure?
- Is vSphere 4 deployed?
- Which other hypervisors are in use: Xen, Hyper-V?
- What management packages are being used?
- What other equipment is accessing the storage arrays?

Before the existing equipment can be supported as Vblock Infrastructure Packages, these questions need to be addressed. A plan would then be developed to remediate the environment to meet Vblock Infrastructure Packages standards.

In practical terms, it may not be possible or desirable to do this depending upon the complexity of the environment; it may be simpler to deploy a new Vblock, migrate workloads first, and then migrate existing storage arrays to that infrastructure over time. Each of these situations would need to be assessed on their relative merits and would require extensive audits.

## Vblock 0 Component Details

This section contains more detailed descriptions of the main components of Vblock 0:

- [Compute—Unified Computing System \(UCS\)](#)
- [Network](#)
  - [Cisco Nexus 1000V](#)
- [Storage](#)
  - [EMC Celerra NS-120](#)
  - [NFS Datastores and Native File Services—EMC Celerra](#)
  - [Cisco Nexus 5010](#)
- [Virtualization](#)

### Compute—Unified Computing System (UCS)

The Cisco Unified Computing System (UCS) is a next-generation data center platform that unites compute, network, and storage access. The platform, optimized for virtual environments, is designed within open industry standard technologies and aims to reduce TCO and increase business agility. The system integrates a low-latency, lossless 10 Gigabit Ethernet unified network fabric with enterprise-class, x86-architecture servers. The system is an integrated, scalable, multichassis platform in which all resources participate in a unified management domain.

### UCS Components

The Cisco Unified Computing System is built from the following components:





- Cisco UCS 6100 Series Fabric Interconnects (<http://www.cisco.com/en/US/partner/products/ps10276/index.html>) is a family of line-rate, low-latency, lossless, 10 Gbps Ethernet and Fibre Channel over Ethernet interconnect switches.
- Cisco UCS 5100 Series Blade Server Chassis (<http://www.cisco.com/en/US/partner/products/ps10279/index.html>) supports up to eight blade servers and up to two Fabric Extenders in a six rack unit (RU) enclosure.

- Cisco UCS 2100 Series Fabric Extenders (<http://www.cisco.com/en/US/partner/products/ps10278/index.html>) bring Unified Fabric into the blade server chassis, providing up to four 10 Gbps connections each between blade servers and the fabric interconnect.
- Cisco UCS B-Series Blade Servers (<http://www.cisco.com/en/US/partner/products/ps10280/index.html>) adapt to application demands, intelligently scale energy use, and offer best-in-class virtualization.
- Cisco UCS B-Series Network Adapters (<http://www.cisco.com/en/US/partner/products/ps10280/index.html>) offer a range of options, including adapters optimized for virtualization, compatibility with existing driver stacks, or efficient, high-performance Ethernet.
- Cisco UCS Manager (<http://www.cisco.com/en/US/partner/products/ps10281/index.html>) provides centralized management capabilities for the Cisco Unified Computing System.

For more information, see: <http://www.cisco.com/en/US/partner/netsol/ns944/index.html>.

Table 1 summarizes the various components that constitute the Cisco UCS.

**Table 1 Cisco Unified Computing System Components**

<p><b>UCS Manager</b> Embedded—Manages entire system</p>	 <p>227092</p>
<p><b>UCS Fabric Interconnect</b> 20 Port 10 Gb FCoE 40 Port 10 Gb FCoE</p>	 <p>227093</p>
<p><b>UCS Fabric Extender</b> Remote line card</p>	 <p>227094</p>
<p><b>UCS Blade Server Chassis</b> Flexible bay configurations</p>	 <p>227095</p>
<p><b>UCS Blade Server</b> Industry-standard architecture</p>	 <p>227096</p>

**Table 1 Cisco Unified Computing System Components**

<p><b>UCS Virtual Adapters</b> Choice of multiple adapters</p>	
--	--

Figure 5 provides an overview of the components of the Cisco UCS.

**Figure 5 Cisco Unified Computing System**

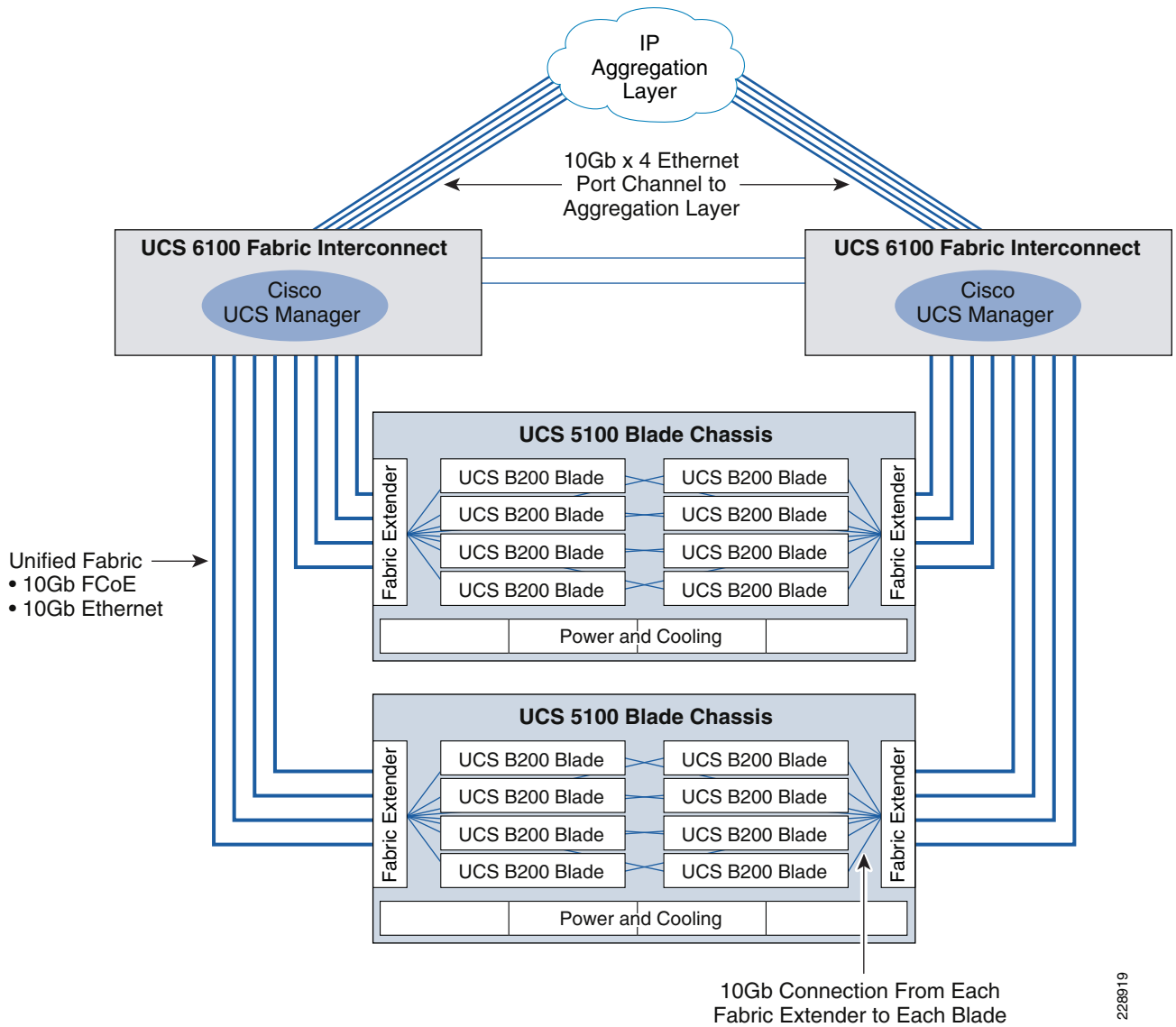

228919

## Cisco UCS and UCS Manager (UCSM)

The Cisco UCS is a revolutionary new architecture for blade server computing. The Cisco UCS is a next-generation data center platform that unites compute, network, storage access, and virtualization into a cohesive system designed to reduce TCO and increase business agility. The system integrates a low-latency, lossless 10 Gigabit Ethernet unified network fabric with enterprise-class, x86-architecture servers. The system is an integrated, scalable, multi-chassis platform in which all resources participate in a unified management domain. Managed as a single system whether it has one server or 320 servers with thousands of virtual machines, the Cisco UCS decouples scale from complexity. The Cisco UCS accelerates the delivery of new services simply, reliably, and securely through end-to-end provisioning and migration support for both virtualized and non-virtualized systems.

### UCS Manager

Data centers have become complex environments with a proliferation of management points. From a network perspective, the access layer has fragmented, with traditional access layer switches, switches in blade servers, and software switches used in virtualization software all having separate feature sets and management paradigms. Most current blade server systems have separate power and environmental management modules, adding cost and management complexity. Ethernet NICs and Fibre Channel HBAs, whether installed in blade server systems or rack-mount servers, require configuration and firmware updates. Blade and rack-mount server firmware must be maintained and BIOS settings must be managed for consistency. As a result, data center environments have become more difficult and costly to maintain, while security and performance may be less than desired. Change is the norm in data centers, but the combination of x86 server architectures and the older deployment paradigm makes change difficult:

- In fixed environments in which servers run OS and application software stacks, rehosting software on different servers as needed for scaling and load management is difficult to accomplish. I/O devices and their configuration, network configurations, firmware, and BIOS settings all must be configured manually to move software from one server to another, adding delays and introducing the possibility of errors in the process. Typically, these environments deploy fixed spare servers already configured to meet peak workload needs. Most of the time these servers are either idle or highly underutilized, raising both capital and operating costs.
- Virtual environments inherit all the drawbacks of fixed environments, and more. The fragmentation of the access layer makes it difficult to track virtual machine movement and to apply network policies to virtual machines to protect security, improve visibility, support per-virtual machine QoS, and maintain I/O connectivity. Virtualization offers significant benefits; however, it adds more complexity.

### Cisco UCS 6100 Series Fabric Interconnects

A core part of the Cisco UCS, the Cisco UCS 6100 Series Fabric Interconnects provide both network connectivity and management capabilities to all attached blade servers and chassis. The Cisco UCS 6100 Series offers line-rate, low-latency, lossless 10 Gigabit Ethernet and Fibre Channel over Ethernet (FCoE) functions.

The interconnects provide the management and communication backbone for the Cisco UCS B-series half-slot blade servers and UCS 5100 Series Blade Server Chassis. All chassis, and therefore all blade servers, attached to the interconnects become part of a single, highly available management domain. In addition, by supporting unified fabric, the Cisco UCS 6100 Series provides both the LAN and SAN connectivity for all blade servers within its domain.

Typically deployed in redundant pairs, fabric interconnects provide uniform access to both networks and storage, eliminating the barriers to deploying a fully virtualized environment. Vblock 0 uses the 20-port 6120XP, which offers the following key features and benefits:

- High performance Unified Fabric with line-rate, low-latency, lossless 10 Gigabit Ethernet, and FCoE.
- Centralized unified management with Cisco UCS Manager software.
- Virtual machine optimized services with the support for VN-Link technologies.
- Efficient cooling and serviceability with front-to-back cooling, redundant front-plug fans and power supplies, and rear cabling.
- Available expansion module options provide Fibre Channel and/or 10 Gigabit Ethernet uplink connectivity.

For more information on the Cisco UCS 6100 Series Fabric Interconnects, see:

<http://www.cisco.com/en/US/products/ps10276/index.html>

### Vblock Infrastructure Packages Configuration and Design Considerations

- Vblock 0—6120 Fabric Interconnect
  - (20) 10 Gb fixed ports to blade server chassis/aggregation layer
  - (4) 4 Gb ports to SAN fabric
- Always configured in pairs for availability and load balancing
- Predictable performance:
  - 4:1 network oversubscription
  - Balanced configuration

### Cisco UCS 5100 Series Blade Server Chassis

The Cisco UCS 5100 Series Blade Server Chassis is a crucial building block of the Cisco UCS, delivering a scalable and flexible architecture for current and future data center needs, while helping reduce total cost of ownership.

Cisco's first blade server chassis offering, the Cisco UCS 5108 Blade Server Chassis, is six rack units (6RU) high and mounts in an industry-standard 19-inch rack. A chassis can accommodate up to either eight half-slot or four full-slot Cisco UCS B-Series Blade Servers, two redundant 2104XP Fabric Extenders, eight cooling fans, and four power supply units. The cooling fans and power supply are hot-swappable and redundant. The chassis requires only two power supplies for normal operation; the additional power supplies are for redundancy. The highly-efficient (in excess of 90%) power supplies, in conjunction with the simple chassis design that incorporates front to back cooling, make the UCS system very reliable and energy efficient.

The Cisco UCS 5108 Blade Server Chassis revolutionizes the use and deployment of blade server-based systems. By incorporating unified fabric and fabric-extender technology, the Cisco Unified Computing System enables the chassis to:

- Have fewer physical components
- Require no independent management
- Be more energy efficient than traditional blade server chassis

This simplicity eliminates the need for dedicated chassis management and blade server switches, reduces cabling, and allowing scalability to 40 chassis without adding complexity. The Cisco UCS 5108 Blade Server Chassis is a critical component in delivering the simplicity and IT responsiveness for the data center as part of the Cisco UCS.

For more information on the Cisco UCS 5100 Series Blade Server Chassis, see:

<http://www.cisco.com/en/US/products/ps10279/index.html>

## Vblock Infrastructure Packages Configuration and Design Considerations

- Vblock 0:
  - 2 blade server chassis
- Availability:
  - Two Fabric Extenders per chassis
  - N+1 cooling and power
- Predictable performance:
  - 2:1 Oversubscription—40 Gb per chassis
  - Balanced configuration
  - Distribute vHBA and vNIC between fabrics

## Cisco UCS B-200 M1 Blade Server

The Cisco UCS B-200 M1<sup>1</sup> Blade Server balances simplicity, performance, and density for production-level virtualization and other mainstream data center workloads. The blade server is a half-width, two-socket blade server with substantial throughput and 50 percent more industry-standard memory compared to previous-generation Intel Xeon two-socket servers.

Features of the Cisco UCS B-200 M1 Blade Server include:

- Up to two Intel® Xeon® 5500 Series processors, which automatically and intelligently adjust server performance according to application needs, increasing performance when needed and achieving substantial energy savings when not.
- Up to 96 GB of DDR3 memory in a half-width form factor for mainstream workloads, which serves to balance memory capacity and overall density.
- Two Small Form Factor (SFF) Serial Attached SCSI (SAS) hard drives available in 73GB 15K RPM and 146 GB 10K RPM versions with an LSI Logic 1064e controller and integrated RAID for ESXi local boot service and local page memory purposes.
- One dual-port mezzanine card for up to 20 Gbps of I/O per blade server. Mezzanine card options include either a Cisco UCS VIC M81KR Virtual Interface Card<sup>2</sup>, a converged network adapter (Emulex or QLogic compatible), or a standard 10 GB Ethernet Adapter.

For more information on the Cisco UCS B-200 M1 Blade Server, see:

<http://www.cisco.com/en/US/products/ps10299/index.html>

1. The M2 blade server will be supported in an upcoming version.

2. Will be included soon.

## Vblock Infrastructure Packages Configuration and Design Considerations

- Vblock 0
  - 4-16 blade servers
  - 32-128 cores
  - 48 GB RAM per blade server
  - 73 GB internal HDD
- Availability:
  - N+1 blade servers per chassis
  - Trunk and Port Group configuration
- One dual port converged network adapter (Unified Network)
  - vNIC
  - vHBA
- Internal connections to both Fabric Extenders
- Predictable performance
  - Dual quad core Xeon 5500 Series processors
  - Balanced configuration
    - Network
    - Memory
    - Compute
- Scalability and flexibility
  - VLAN, Trunks and Port Groups

## Network

### Cisco Nexus 1000V

The Nexus 1000V (<http://www.cisco.com/en/US/products/ps9902/index.html>) is a software switch on a server that delivers Cisco VN-Link (<http://www.cisco.com/en/US/netsol/ns894/index.html>) services to virtual machines hosted on that server. It takes advantage of the VMware vSphere (<http://www.cisco.com/survey/exit.html?http://www.vmware.com/products/cisco-nexus-1000V/index.html>) framework to offer tight integration between server and network environments and help ensure consistent, policy-based network capabilities to all servers in the data center. It allows policies to move with a virtual machine during live migration, ensuring persistent network, security, and storage compliance, resulting in improved business continuance, performance management, and security compliance. Last but not least, it aligns management of the operational environment for virtual machines and physical server connectivity in the data center, reducing the total cost of ownership (TCO) by providing operational consistency and visibility throughout the network. It offers flexible collaboration between the server, network, security, and storage teams while supporting various organizational boundaries and individual team autonomy.

For more information, see: <http://www.cisco.com/en/US/products/ps9902/index.html>.

## Storage

Storage components include:

- [EMC Celerra NS-120](#)
- [NFS Datastores and Native File Services—EMC Celerra](#)
- [Cisco Nexus 5010](#)

## EMC Celerra

- Storage configurations are application-specific
- Logical device considerations
  - LUN size
    - Consistent size based on application requirements
  - RAID protection
    - RAID 1
    - RAID 5
    - RAID 6
  - LUN aggregation using meta devices
    - Size
    - Performance
  - Virtual Provisioning
    - Thin pool
    - Thin devices/fully allocated
- Simplifies storage provisioning
  - Storage tiers based on drive and protection
  - Storage templates
  - Storage policies
- Local and remote replication requirements

## EMC Celerra NS-120

[Figure 3](#) illustrates the EMC Celerra NS-120 in Vblock 0.

The EMC Celerra NS-120 Unified Storage system brings advanced failover and fully automated storage tiering to multi-protocol environments. With Celerra NS-120, you can connect to multiple storage networks via NAS, iSCSI, Fibre Channel SAN, and EMC Celerra Multi-Path File System (MPFS). MPFS improves performance over traditional NAS.

### Gaining the Flexibility of NFS without Compromise

EMC Celerra was originally developed to provide customers with the same levels of availability, reliability, performance, and scalability for file shares that they had come to rely on in their EMC Symmetrix block-storage systems. Specifically, general purpose and appliance servers were not

sufficient for running mission-critical engineer and manufacturing operations. Celerra has since evolved to be the industry-leading NAS system. Moreover, the attributes that make Celerra the preferred infrastructure for mission-critical file-sharing applications also make it the best storage infrastructure for deploying VMware.

## Infrastructure for VMware

Key attributes of an NFS and iSCSI infrastructure for VMware include:

- **Availability**—Storage systems must deliver high availability and advanced features to ensure virtualized application performance.
- **Protection**—The infrastructure must maintain virtualized application availability and protect information without adversely affecting business operations.
- **Efficiency**—One of the key benefits of VMware is improved provisioning and operational efficiency. The storage infrastructure must be able to extend efficiencies to storage management.
- **Flexibility**—Virtualized infrastructures enable rapid changes in application deployments and resource allocation. The infrastructure must be able to respond to changes in storage capacity, performance, and protection requirements. Thin provisioning is available for both block-level iSCSI as well as file-level NFS.
- **Manageability**—One of the benefits of deploying VMware on NFS and iSCSI is consolidated storage management. The NFS solution must provide simplified and automated management and extend this by integrating control into the VMware vCenter™ Console, while iSCSI is fully manageable from the Celerra Manager GUI.
- **Service and support**—The infrastructure provider must be capable of ensuring that customers realize the value of their virtualized infrastructures while reducing risk and accelerating projects.

For more information, see: <http://www.emc.com/products/detail/hardware/celerra-ns960.htm>.

## NFS Datastores and Native File Services—EMC Celerra

Performance bottlenecks, security issues, and the high cost of data protection and management associated with deploying file servers using general-purpose operating systems become non-issues with the EMC Celerra Gateway family. Each Celerra NS-120 is a dedicated network server optimized for file access and advanced functionality in a scalable, easy-to-use package. Best-in-class EMC CLARiiON back-end array technologies, combined with Celerra's impressive I/O system architecture, deliver industry-leading availability, scalability, performance, and ease of management to your business.

Celerra NS-120 delivers a comprehensive, consolidated storage solution that adds IP storage (NAS) in a centrally-managed information storage system, enabling you to dynamically grow, share, and cost-effectively manage file systems with multi-protocol file access. Take advantage of simultaneous support for NFS and CIFS protocols by letting UNIX and Microsoft® Windows® clients share files using the DART (Data Access in Real Time) operating system's sophisticated file-locking mechanisms. The high-end features offered with the Celerra platform enable entry-level data center consolidation resulting in lower total TCO of your server and storage assets—while enabling you to grow your IP storage environment into the hundreds of TB from a single point of management. And you can improve performance over standard NAS by simply adding MPFS to your environment without application modification.

The EMC Celerra NS-120 platform combines a NAS head and SAN storage for a flexible, cost-effective implementation that maximizes the utilization of your existing resources. This approach offers the utmost in configuration options, including:

- Dual blade configuration

- SATA disk for inexpensive expansion
- Performance/availability mode
- EMC CLARiiON storage

### Optional IP Replication Between Vblock 0 EMC Celerra NS-120 System Elements

The Celerra NS-120 is composed of two autonomous servers called X-Blades that connect via FC SAN to a CLARiiON storage array. The X-Blades control data movement from the disks to the network. Each X-Blade consists of an Intel-based server with redundant data paths, power supplies, and multiple Gigabit Ethernet ports. X-Blades run EMC's Data Access in Real Time (DART) operating system, designed and optimized for high-performance and multi-protocol network file access. All the X-Blades in a system are managed by the Control Station (two control stations for HA are supported in Vblock 0), which operates out of the data path and provides a single point of configuration management and administration as well as handling X-Blade failover and maintenance support.

### Cisco Nexus 5010

Figure 3 illustrates the interconnection of the Cisco Nexus 5010 in Vblock 0.

The innovative architecture of the Cisco Nexus 5010 Series Switches simplifies data center transformation by helping to enable a standards-based, high-performance unified fabric. Next-generation data centers increasingly have dense, multi-core, virtual-machine-intensive servers.

With these switches, you can:

- Consolidate the data center and protect investments in existing server, network, storage, and facilities assets
- Decrease the TCO by simplifying the data center infrastructure
- Increase business agility with easier, faster, and pervasive data center virtualization
- Enhance business resilience with greater operational continuity
- Use existing operational models and administrative domains for easy deployment

For more information, see: <http://www.cisco.com/en/US/products/ps9670/index.html>.

### Storage Design Considerations

- Balanced configuration
  - Capacity, connectivity, workload (IOPs/MBs)
- Availability
  - Enterprise class storage
  - RAID protection
  - Extensive remote replication capabilities using MirrorView™ and SRDF®
- Predictable performance
  - Large cache
  - Tiered storage including Enterprise Flash Drives
- Ease of deployment and management
  - Template-based provisioning

- Wizards
- Fully Automated Storage Tiering (FAST)
- Virtual Provisioning™
- Local replication capability using SnapView™ and TimeFinder®

## Virtualization

### VMware vSphere

- VMware vSphere 4 is the virtualized infrastructure for the Vblock Infrastructure Packages
  - Virtualizes all application servers
  - Provides VMware High Availability (HA) and Dynamic Resource Scheduling (DRS)
- Templates enable rapid provisioning

### VMware ESXi and vCenter Server

VMware ESXi and vCenter Server offer the highest levels of availability and responsiveness for all applications and services and are the industry's most reliable platform for data center virtualization. Optimize IT service delivery and deliver the highest levels of application service agreements with the lowest total cost per application workload by decoupling your business-critical applications from the underlying hardware for unprecedented flexibility and reliability.

VMware vCenter Server provides a scalable and extensible platform that forms the foundation for virtualization management (<http://www.vmware.com/solutions/virtualization-management/>). VMware vCenter Server centrally manages VMware vSphere (<http://www.vmware.com/products/vsphere/>) environments, allowing IT administrators dramatically improved control over the virtual environment compared to other management platforms. VMware vCenter Server:

- Provides centralized control and visibility at every level of virtual infrastructure.
- Unlocks the power of vSphere through proactive management.
- Is a scalable and extensible management platform with a broad partner ecosystem.

For more information, see <http://www.vmware.com/products/>.

# Vblock 0 Configuration—Rack Layout Front View

- 2 UCS Chassis, 4-16 blade servers total, 48 GB RAM per blade server
- 2 UCS 6120 Fabric Interconnect, 20 fixed ports, 8 ports 4 GB Fibre Channel
- 1 or 2 Celerra NS-120
- 2 Cisco Nexus 5010

**Figure 6** Vblock 0—Rack Layout Front View

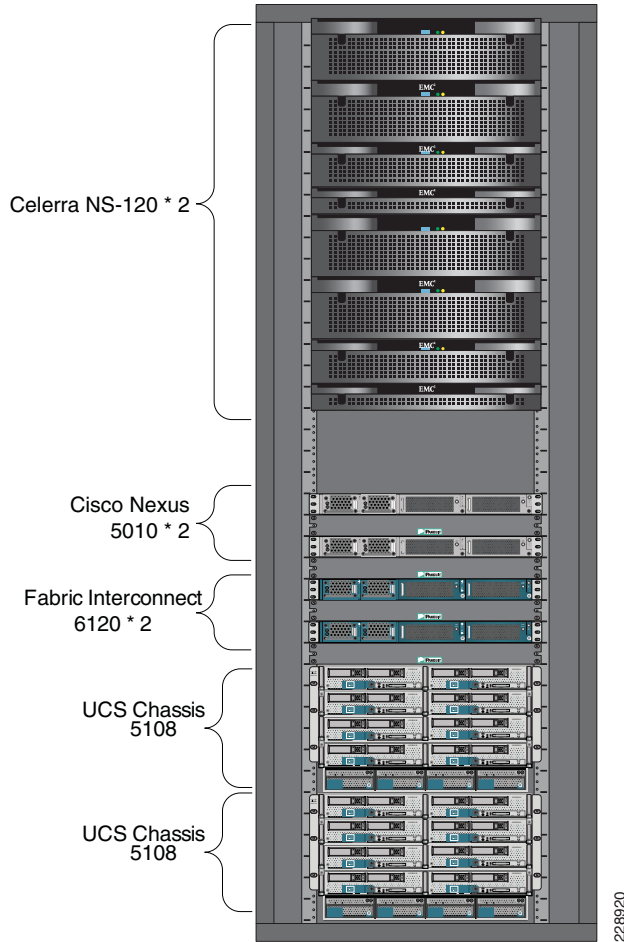

## References

- VMware View Reference Architecture  
<http://www.vmware.com/resources/techresources/1084>
- VMware View 4.0  
<http://www.vmware.com/products/view/>
- Cisco UCS  
<http://www.cisco.com/go/unifiedcomputing>
- Cisco Data Center Solutions  
<http://www.cisco.com/go/datacenter>
- Cisco Validated Designs  
<http://www.cisco.com/go/designzone>
- EMC CLARiiON Family  
<http://www.emc.com/products/family/clariion-family.htm>
- EMC Celerra Family  
<http://www.emc.com/products/family/celerra-family.htm>
- EMC Symmetrix VMAX System  
<http://www.emc.com/products/detail/hardware/symmetrix-vmax.htm>
- EMC Symmetrix VMAX System and VMware Virtual Infrastructure white paper  
<http://www.emc.com/collateral/hardware/white-papers/h6209-symmetrix-v-max-vmware-virtual-Infrastructure-wp.pdf>
- Using EMC Symmetrix Storage in VMware Infrastructure and vSphere Environments  
<http://www.emc.com/collateral/hardware/solution-overview/h2529-vmware-esx-svr-w-symmetrix-wp-ldv.pdf>



Cisco Systems, Inc.  
170 West Tasman Drive  
San Jose, CA 95134 USA  
Tel: 408-526-4000 or 800-553-6387  
(NETS)  
Fax: 408-527-0883  
[www.cisco.com](http://www.cisco.com)



EMC Corporation  
176 South Street  
Hopkinton, MA 01748 USA  
Tel: 508-435-1000  
[www.emc.com](http://www.emc.com)



VMware, Inc.  
3401 Hillview Ave  
Palo Alto, CA 94304 USA  
Tel: 650-427-5000 or 877-486-9273  
Fax: 650-427-5001  
[www.vmware.com](http://www.vmware.com)

Copyright © 2010 Cisco Systems, Inc. All rights reserved. Cisco, the Cisco logo, and Cisco Systems are registered trademarks or trademarks of Cisco Systems, Inc. and/or its affiliates in the United States and certain other countries. All other trademarks mentioned in this document or Website are the property of their respective owners. The use of the word partner does not imply a partnership relationship between Cisco and any other company.

Copyright © 2010 EMC Corporation. All rights reserved. EMC2, EMC, Celerra, CLARiiON, Ionix, MirrorView, Navisphere, PowerPath, SnapView, SRDF, Symmetrix, TimeFinder, Virtual Provisioning, VMAX and where information lives are registered trademarks or trademarks of EMC Corporation in the United States or other countries. All other trademarks used herein are the property of their respective owners. Published in the USA. P/N h7189

Copyright © 2010 VMware, Inc. All rights reserved. This product is protected by U.S. and international copyright and intellectual property laws. VMware products are covered by one or more patents listed at <http://www.vmware.com/go/patents>. VMware is a registered trademark or trademark of VMware, Inc. in the United States and/or other jurisdictions. All other marks and names mentioned herein may be trademarks of their respective companies.